

# **EUCHNER**

## **Operating Instructions**

**Transponder-Coded Safety Switch With Guard Locking**  
**CTP-AP Unicode/Multicode**

**EN**

## Contents

<b>1.</b>	<b>About this document</b> .....	<b>4</b>
1.1.	Scope.....	4
1.2.	Target group .....	4
1.3.	Key to symbols.....	4
1.4.	Supplementary documents .....	4
<b>2.</b>	<b>Correct use</b> .....	<b>5</b>
<b>3.</b>	<b>Description of the safety function</b> .....	<b>6</b>
<b>4.</b>	<b>Exclusion of liability and warranty</b> .....	<b>7</b>
<b>5.</b>	<b>General safety precautions</b> .....	<b>7</b>
<b>6.</b>	<b>Function</b> .....	<b>8</b>
6.1.	Guard lock monitoring .....	8
6.2.	Door position monitoring output (OD).....	8
6.3.	Diagnostic monitoring output (OI) .....	8
6.4.	Guard lock monitoring output (OL).....	8
6.5.	Version CTP Extended.....	8
6.6.	Guard locking on version CTP-L1.....	8
6.7.	Guard locking on version CTP-L2.....	9
6.8.	Switching states .....	9
<b>7.</b>	<b>Manual release</b> .....	<b>10</b>
7.1.	Auxiliary release and auxiliary key release .....	10
7.1.1.	Actuating auxiliary release .....	10
7.1.2.	Actuating auxiliary key release .....	10
7.2.	Emergency release .....	11
7.2.1.	Actuating emergency release .....	11
7.3.	Escape release (optional) .....	11
7.3.1.	Actuating escape release.....	11
7.4.	Wire front release (bowden) .....	11
7.4.1.	Laying wire front release.....	12
<b>8.</b>	<b>Changing the approach direction</b> .....	<b>13</b>
<b>9.</b>	<b>Mounting</b> .....	<b>14</b>
<b>10.</b>	<b>Electrical connection</b> .....	<b>15</b>
10.1.	Notes about  .....	16
10.2.	Safety in case of faults.....	16
10.3.	Fuse protection for power supply .....	16
10.4.	Requirements for connecting cables.....	17
10.5.	Connector assignment of safety switch CTP-...-AP-...-SAB-... with plug connectors 2 x M12.....	18

10.6.	Connector assignment of safety switch CTP-...-AP-...-SH-... with plug connector M23 (RC18).....	18
10.7.	Connector assignment of safety switch CTP-...-AP-...-SA-... with plug connector M12, 8-pin.....	18
10.8.	Connector assignment of safety switch CTP-...-AP-...-SII-... with plug connectors 2 x M12, 5-pin.....	19
10.9.	Connection of CTP-AP .....	19
10.10.	Notes on operation with safe control systems.....	20
10.11.	Connection of guard locking control .....	21
	10.11.1. Guard locking control for variants with IMM connection .....	21
	10.11.2. Guard locking control for variants without IMM connection.....	21
<b>11.</b>	<b>Setup .....</b>	<b>22</b>
11.1.	LED displays .....	22
11.2.	Teach-in function for actuator (only for unicode evaluation) .....	22
	11.2.1. Actuator teach-in.....	22
11.3.	Functional check.....	23
	11.3.1. Mechanical function test.....	23
	11.3.2. Electrical function test.....	23
<b>12.</b>	<b>System status table .....</b>	<b>24</b>
<b>13.</b>	<b>Technical data .....</b>	<b>25</b>
13.1.	Technical data for safety switch CTP-AP .....	25
	13.1.1. Typical system times.....	26
13.2.	Radio frequency approvals.....	27
13.3.	Dimension drawing for safety switch CTP.....	28
13.4.	Technical data for actuator CTP-... .....	30
	13.4.1. Dimension drawing for actuator CTP-.....	30
<b>14.</b>	<b>Ordering information and accessories .....</b>	<b>33</b>
<b>15.</b>	<b>Inspection and service .....</b>	<b>33</b>
<b>16.</b>	<b>Service .....</b>	<b>33</b>
<b>17.</b>	<b>Declaration of conformity .....</b>	<b>34</b>

## 1. About this document





### 1.1. Scope

These operating instructions are valid for all CTP-L-AP... from version V1.0.0. These operating instructions, the document *Safety information* and any enclosed data sheet form the complete user information for your device.

### 1.2. Target group



Design engineers and installation planners for safety devices on machines as well as setup and servicing staff possessing special expertise in handling safety components.

### 1.3. Key to symbols

Symbol/depiction	Meaning
	Printed document
	Document is available for download at <a href="http://www.euchner.com">www.euchner.com</a>
 <b>DANGER</b> <b>WARNING</b> <b>CAUTION</b>	Safety precautions <b>Danger</b> of death or severe injuries <b>Warning</b> about possible injuries <b>Caution</b> slight injuries possible
 <b>NOTICE</b> <b>Important!</b>	<b>Notice</b> about possible device damage <b>Important</b> information
<b>Tip</b>	Useful information

### 1.4. Supplementary documents

The overall documentation for this device consists of the following documents:

Document title (document number)	Contents	
Safety information (2525460)	Basic safety information	
Operating instructions (2124217)	(this document)	
Possibly enclosed data sheet	Item-specific information about deviations or additions	

	<b>Important!</b>  Always read all documents to gain a complete overview of safe installation, setup and use of the device. The documents can be downloaded from <a href="http://www.euchner.com">www.euchner.com</a> . For this purpose enter the doc. no. in the search box.
---	--

### 2. Correct use

Safety switches series CTP-L-... are interlocking devices with guard locking solenoid (type 4). The device complies with the requirements according to EN IEC 60947-5-3. Devices with unicode evaluation possess a high coding level, devices with multicode evaluation possess a low coding level.

In combination with a movable guard and the machine control, this safety component prevents the guard from being opened while a dangerous machine function is being performed.

This means:

- Starting commands that cause a dangerous machine function must become active only when the guard is closed and locked.
- The guard locking must not be released until the dangerous machine function has ended.
- Closing and locking a guard must not cause automatic starting of a dangerous machine function. A separate start command must be issued. For exceptions, refer to EN ISO 12100 or relevant C-standards.

Devices from this series are also suitable for process protection.

Before the device is used, a risk assessment must be performed on the machine, e.g. in accordance with the following standards:

- EN ISO 13849-1
- EN ISO 12100
- IEC 62061

Correct use includes observing the relevant requirements for installation and operation, particularly based on the following standards:

- EN ISO 13849-1
- EN ISO 14119
- EN 60204-1

The safety switch is allowed to be operated only in conjunction with the intended EUCHNER actuator and the related connection components from EUCHNER. On the use of different actuators or other connection components, EUCHNER provides no warranty for safe function.



**Important!**

- The user is responsible for the proper integration of the device into a safe overall system. For this purpose, the overall system must be validated, e.g. in accordance with EN ISO 13849-2.
- It is only allowed to use components that are permissible in accordance with the table below.

Table 1: Possible combinations for CTP components

Safety switch	Actuator	
	A-C-H...	
CTP-... Unicode/Multicode	●	
<b>Key to symbols</b>	●	Combination possible

### 3. Description of the safety function

Devices from this series feature the following safety functions:

#### Monitoring of guard locking and the position of the guard (interlocking device with guard locking according to EN ISO 14119)

- Safety function (see chapter 6.8. *Switching states on page 9*):
  - The safety outputs are switched off when guard locking is released (monitoring of the locking element).
  - The safety outputs are switched off when the guard is open (monitoring of the door position).
  - Guard locking can be activated only when the actuator is located in the switch head (prevention of inadvertent locking position (faulty closure protection)).
- Safety characteristics: category, Performance Level, PFH<sub>D</sub> (see chapter 13. *Technical data on page 25*).

#### Control of guard locking

If the device is used as guard locking for personnel protection, the control of the guard locking must be regarded as a safety function.

The device does not feature a safety characteristic for the control of the guard locking, because the guard locking solenoid is completely disconnected from outside the device (no control function within the device). It therefore does not contribute to the failure probability.

The safety level for the control of the guard locking is defined only by the external control (e.g. PFH<sub>D, ext.</sub> for the standstill monitor).

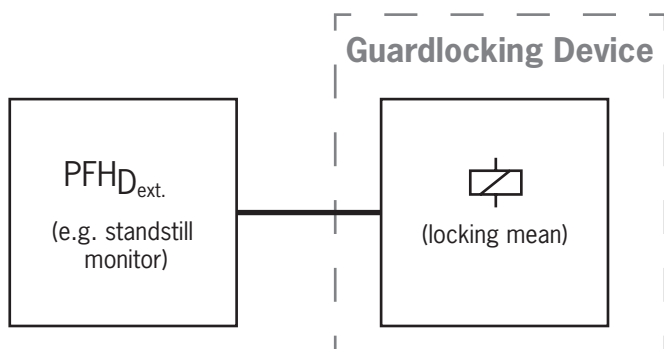

## 4. Exclusion of liability and warranty

In case of failure to comply with the conditions for correct use stated above, or if the safety regulations are not followed, or if any servicing is not performed as required, liability will be excluded and the warranty void.

## 5. General safety precautions

Safety switches fulfill personnel protection functions. Incorrect installation or tampering can lead to fatal injuries to personnel.

Check the safe function of the safeguard particularly

- › after any setup work
- › after the replacement of a system component
- › after an extended period without use
- › after every fault

Independent of these checks, the safe function of the safeguard should be checked at suitable intervals as part of the maintenance schedule.



### WARNING

Danger to life due to improper installation or due to bypassing (tampering). Safety components fulfill a personnel protection function.

- › Safety components must not be bypassed, turned away, removed or otherwise rendered ineffective. On this topic pay attention in particular to the measures for reducing the possibility of bypassing according to EN ISO 14119:2013, section 7.
- › The switching operation must be triggered only by actuators designated for this purpose.
- › Prevent bypassing by means of replacement actuators (only for multicode evaluation). For this purpose, restrict access to actuators and to keys for releases, for example.
- › Mounting, electrical connection and setup only by authorized personnel possessing the following knowledge:
  - specialist knowledge in handling safety components
  - knowledge about the applicable EMC regulations
  - knowledge about the applicable regulations on operational safety and accident prevention



### Important!

Prior to use, read the operating instructions and keep these in a safe place. Ensure the operating instructions are always available during mounting, setup and servicing. For this reason you should archive a printed copy of the operating instructions. You can download the operating instructions from [www.euchner.com](http://www.euchner.com).

## 6. Function

The device permits the locking of movable guards.

The system consists of the following components: coded actuator (transponder) and switch.

Whether the device learns the complete actuator code (unicode) or not (multicode) depends on the respective version.

- ▶ **Devices with unicode evaluation:** The actuator must be assigned to the safety switch by a teach-in operation so that it is detected by the system. This unambiguous assignment ensures a particularly high level of protection against tampering. The system thus possesses a high coding level.
- ▶ **Devices with multicode evaluation:** Unlike systems with unicode evaluation, on multicode devices a specific code is not requested but instead it is only checked whether the actuator is of a type that can be detected by the system (multicode evaluation). There is no exact comparison of the actuator code with the taught-in code in the safety switch (unicode evaluation). The system possesses a low coding level.

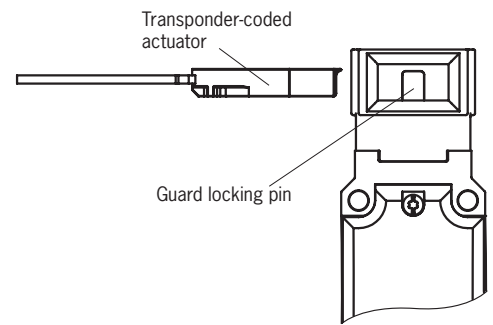

When the guard is closed, the actuator is moved into the safety switch. When the operating distance is reached, power is supplied to the actuator by the switch and data are transferred.

If a permissible code is detected, the safety outputs  are switched on.

The safety outputs  and the monitoring output (OL) are switched off when the guard is released.

In the event of a fault in the safety switch, the safety outputs  are switched off and the DIA LED illuminates red. The occurrence of faults is detected at the latest on the next demand to close the safety outputs (e.g. on starting).

### 6.1. Guard lock monitoring

All versions feature two safe outputs for monitoring guard locking. The safety outputs  F01A and F01B are switched off when guard locking is released.

### 6.2. Door position monitoring output (OD)

The door position monitoring output is switched on as soon as the actuator is inserted into the switch head (state: guard closed and not locked). The door position monitoring output also remains switched on when guard locking is active.

### 6.3. Diagnostic monitoring output (OI)

The diagnostic monitoring output is switched on in the event of a fault (switch-on condition as for DIA LED).

### 6.4. Guard lock monitoring output (OL)

The guard lock monitoring output is switched on when guard locking is active.

### 6.5. Version CTP Extended

Devices in the Extended version contain additional controls/indicators in the housing cover. Please refer to the enclosed data sheet for further information.

### 6.6. Guard locking on version CTP-L1

(guard locking actuated by spring force and released by power-ON)

**Activating guard locking:** close guard; no voltage at the solenoid.

**Releasing guard locking:** apply voltage to the solenoid.

The spring-operated guard locking functions in accordance with the closed-circuit current principle. If the voltage is interrupted at the solenoid, the guard locking remains active and the guard cannot be opened directly.



#### Important!

If the guard is open when the power supply is interrupted and is then closed, guard locking is activated. This can lead to persons being locked in unintentionally.



The actuator cannot be pulled out of the switch and the guard is locked as long as the guard locking pin is extended.  
If a voltage is applied to the guard locking solenoid, the guard locking pin is retracted and the actuator is released. The guard can be opened.

### 6.7. Guard locking on version CTP-L2

(guard locking actuated by power-ON and released by spring force)



#### Important!

Use as guard locking for personnel protection is possible only in special cases, after strict assessment of the accident risk (see EN ISO 14119:2013, section 5.7.1)!

**Activating guard locking:** apply voltage to the solenoid.

**Releasing guard locking:** disconnect voltage from the solenoid.

The magnetically actuated guard locking operates in accordance with the open-circuit current principle. If the voltage is interrupted at the solenoid, the guard locking is released and the guard can be opened directly!

The guard can be opened as long as no voltage is applied to the guard locking solenoid.

If a voltage is applied to the guard locking solenoid, the guard locking pin is held in the extended position and the guard is locked.

### 6.8. Switching states

The detailed switching states for your switch can be found in the system status table. All safety outputs, monitoring outputs and display LEDs are described there.

	Guard closed and locked	Guard closed and not locked	Guard open
Voltage on guard locking solenoid CTP-L1	off	on	(irrelevant)
Voltage on guard locking solenoid CTP-L2	on	off	(irrelevant)
Safety outputs F01A and F01B	on	off	off
Guard lock monitoring output OL	on	off	off
Door position monitoring output OD	on	on	off

## 7. Manual release



### Important!



No further release functions can be retrofitted on Extended variants with control elements in position 1 (S1) and position 2 (S2).

Some situations require the guard locking to be released manually (e.g. malfunctions or an emergency). A function test should be performed after release.

More information on this topic can be found in the standard EN ISO 14119:2013, section 5.7.5.1. The device can feature the following release functions:

### 7.1. Auxiliary release and auxiliary key release

In the event of malfunctions, the guard locking can be released with the auxiliary release or the auxiliary key release irrespective of the state of the solenoid.

The safety outputs  are switched off when the auxiliary release or auxiliary key release is actuated. Use the safety outputs  to generate a stop command.

The monitoring output OL is switched off; OD can assume an undefined state. Open the guard and close it again after re-setting the auxiliary release or auxiliary key release. The device will then operate normally again.



### Important!

- › The actuator must not be under tensile stress during manual release.
- › After use, reset the auxiliary release and screw in and seal the locking screw (e.g. with sealing lacquer).
- › The auxiliary key release must not be used to lock the switch during servicing to prevent activation of guard locking, for example.
- › Loss of the release function due to mounting errors or damage during mounting.
- › Check the release function every time after mounting.
- › Please observe the notes on any enclosed data sheets.

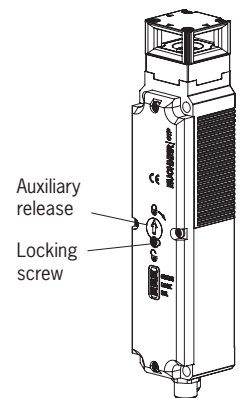

#### 7.1.1. Actuating auxiliary release

1. Unscrew locking screw.
  2. Using a screwdriver, turn the auxiliary release to  in the direction of the arrow.
- ➔ Guard locking is released.

#### 7.1.2. Actuating auxiliary key release

On devices with auxiliary key release (can be retrofitted), simply turn the key to release. Function as for auxiliary release. For mounting, see the auxiliary key release supplement.

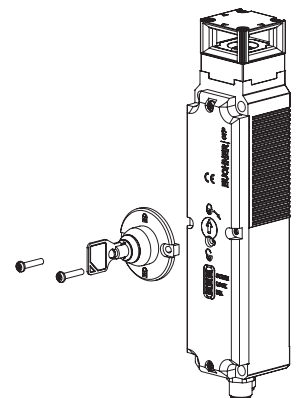

### 7.2. Emergency release

Permits opening of a locked guard from outside the danger zone without tools. For mounting, see the mounting supplement.



#### Important!

- › It must be possible to operate the emergency release manually from outside the protected area without tools.
- › The emergency release must possess a marking indicating that it may be used only in an emergency.
- › The actuator must not be under tensile stress during manual release.
- › The emergency release must be sealed or the misuse of the release function must be prevented in the control system.
- › The release function meets all other requirements from EN ISO 14119.
- › The emergency release meets the requirements of Category B according to EN ISO 13849-1:2015.
- › Loss of the release function due to mounting errors or damage during mounting.
- › Check the release function every time after mounting.
- › Please observe the notes on any enclosed data sheets.

#### 7.2.1. Actuating emergency release

- › Turn the emergency release clockwise until it clicks into place.
- ➔ Guard locking is released.

To reset, press the snap-in bolt inward using a small screwdriver or similar tool and turn the emergency release back.

The safety outputs are switched off when the emergency release is actuated. Use the safety outputs to generate a stop command.

The monitoring output OL is switched off; OD can assume an undefined state. Open the guard and close it again after resetting the emergency release. The device will then operate normally again.

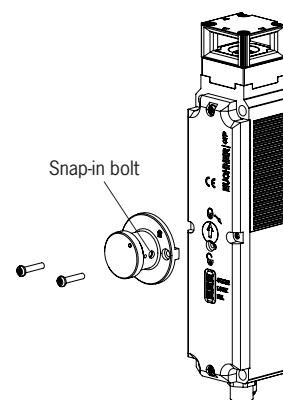

### 7.3. Escape release (optional)

Permits opening of a locked guard from the danger zone without tools (see chapter 13.3. *Dimension drawing for safety switch CTP... on page 28*).



#### Important!

- › It must be possible to operate the escape release manually from inside the protected area without tools.
- › It must not be possible to reach the escape release from the outside.
- › The actuator must not be under tensile stress during manual release.
- › The escape release meets the requirements of Category B according to EN ISO 13849-1:2015.

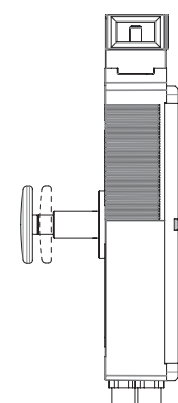

#### 7.3.1. Actuating escape release

- › Press the red release knob to the end stop.
- ➔ Guard locking is released.

Pull the knob out again to reset.

The safety outputs are switched off when the escape release is actuated. Use the safety outputs to generate a stop command.

The monitoring output OL is switched off; OD can assume an undefined state. Open the guard and close it again after resetting the escape release. The device will then operate normally again.

### 7.4. Wire front release (bowden)

Release via a pull wire. Depending on the type of attachment, the wire front release can be used as an emergency release or escape release.

The following applies to non-latching wire front releases.

If the release is to be used as an emergency release, one of the following measures must be taken (see EN ISO 14119:2013, section 5.7.5.3):

- › Install the release so that it can be reset only with the aid of a tool.
- › Alternatively, resetting can be realized at the control-system level by means of a plausibility check (status of the safety outputs does not match the guard locking control signal), for example.

The emergency-release specifications in chapter 7.2 on Page 11 apply irrespective of this information.

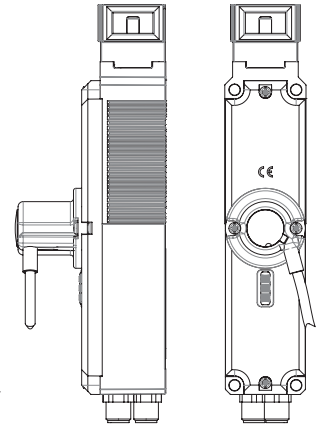

**Important!**

- › The wire front release meets the requirements of Category B according to EN ISO 13849-1:2015.
- › The correct function depends on the laying of the pull wire and the attachment of the pull handle, and this is the responsibility of the plant manufacturer.
- › The actuator must not be under tensile stress during manual release.

**7.4.1. Laying wire front release**



**Important!**

- › Loss of the release function due to mounting errors, damage or wear.
- › Check the release function every time after mounting.
- › When routing the wire front release, ensure that it operates smoothly.
- › Observe the min. bending radius (100 mm) and minimize the number of bends.
- › The switch is not allowed to be opened.
- › Please observe the notes on the enclosed data sheets.

### 8. Changing the approach direction

The approach direction needs to be changed only if the switch is to be approached from the rear.

Proceed as follows:

1. Remove the screws from the safety switch.
2. Set the required direction.
3. Tighten the screws with a torque of 1.2 Nm.

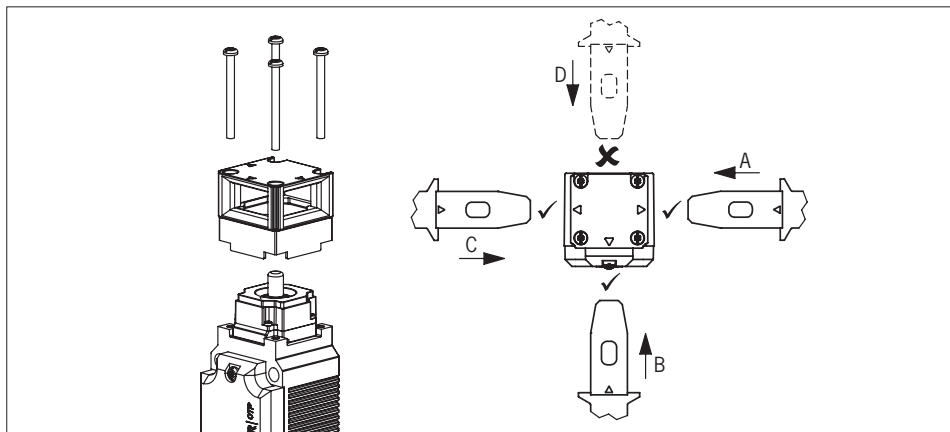

Figure 1: Changing the approach direction

## 9. Mounting



### CAUTION

Safety switches must not be bypassed (bridging of contacts), turned away, removed or otherwise rendered ineffective.

- › Observe EN ISO 14119:2013, section 7, for information about reducing the possibilities for bypassing an interlocking device.



### NOTICE

Risk of damage to equipment and malfunctions as a result of incorrect installation.

- › Safety switches and actuators must not be used as an end stop.
- › Observe EN ISO 14119:2013, sections 5.2 and 5.3, for information about mounting the safety switch and the actuator.
- › Protect the switch head against damage, as well as penetrating foreign objects such as swarf, sand and blasting shot, etc.
- › Observe the min. door radii (see chapter 13.4.1. *Dimension drawing for actuator CTP-... on page 30*).
- › Observe the tightening torque for mounting the switch (max.1.4 Nm).

A clearance of 12 mm must be maintained around the actuator head (see *Figure 2*).

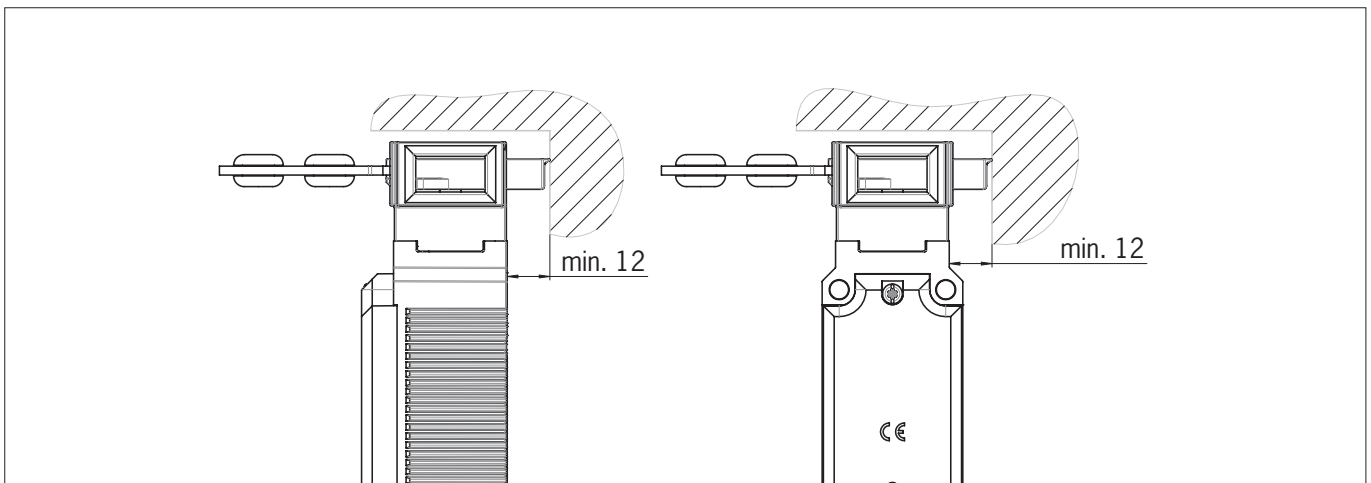



Figure 2: Actuator head clearance

### 10. Electrical connection

	<p><b>WARNING</b></p> <p>In the event of a fault, loss of the safety function due to incorrect connection.</p> <ul style="list-style-type: none"> <li>› To ensure safety, both safety outputs  FO1A and FO1B must always be evaluated.</li> <li>› Monitoring outputs must not be used as safety outputs.</li> <li>› Lay the connecting cables with protection to prevent the risk of short circuits.</li> </ul>
	<p><b>CAUTION</b></p> <p>Risk of damage to equipment or malfunctions as a result of incorrect connection.</p> <ul style="list-style-type: none"> <li>› The power supply for the evaluation electronics is electrically isolated from the power supply for the guard locking solenoid.</li> <li>› The device generates its own test pulses on the output lines FO1A/FO1B. A downstream control system must tolerate these test pulses, which may have a length of up to 0.35 ms. Depending on the inertia of the downstream device (control system, relay, etc.), this can lead to short switching processes.</li> <li>› The inputs on an evaluation unit connected must be positive-switching, as the two outputs on the safety switch deliver a level of +24 V in the switched-on state.</li> <li>› All the electrical connections must either be isolated from the mains supply by a safety transformer according to IEC 61558-2-6 with limited output voltage in the event of a fault, or by other equivalent isolation measures (PELV).</li> <li>› All electrical outputs must have an adequate protective circuit for inductive loads. The outputs must be protected with a free-wheeling diode for this purpose. RC interference suppression units must not be used.</li> <li>› Power devices which are a powerful source of interference must be installed in a separate location away from the input and output circuits for signal processing. The cable routing for safety circuits should be as far away as possible from the cables of the power circuits.</li> <li>› To avoid EMC interference, the physical environmental and operating conditions at the installation site of the device must comply with the requirements according to the standard EN 60204-1:2006, section 4.4.2 (EMC).</li> <li>› Pay attention to any interference fields from devices such as frequency converters or induction heating systems. Observe the EMC instructions in the manuals from the respective manufacturer.</li> </ul>
	<p><b>Important!</b></p> <p>If the device does not appear to function when operating voltage is applied (e.g. green STATE LED does not flash), the safety switch must be returned unopened to the manufacturer.</p>

## 10.1. Notes about



### Important!

- › This device is intended to be used with a Class 2 power source in accordance with UL1310. As an alternative an LV/C (Limited Voltage/Current) power source with the following properties can be used:  
This device shall be used with a suitable isolating source in conjunction with a fuse in accordance with UL248. The fuse shall be rated max. 3.3 A and be installed in the max. 30 V DC power supply to the device in order to limit the available current to comply with the UL requirements. Please note possibly lower connection ratings for your device (refer to the technical data).
- › For use and application as per the requirements of UL <sup>1)</sup> a connecting cable listed under the UL category code CYJV/7 must be used.

1) Note on the scope of the UL approval: the devices have been tested as per the requirements of UL508 and CSA/ C22.2 no. 14 (protection against electric shock and fire).

## 10.2. Safety in case of faults

- › The operating voltage  $U_B$  and the solenoid voltage  $IMP$  are reverse polarity protected.
- › The safety outputs  $FO1A/FO1B$  are short circuit-proof.
- › A short circuit between  $FO1A$  and  $FO1B$  is detected by the switch.
- › A short circuit in the cable can be excluded by laying the cable with protection.

## 10.3. Fuse protection for power supply

The power supply must be provided with fuse protection depending on the number of switches and the current required for the outputs. The following rules apply:

### Max. current consumption $I_{max}$

$$I_{max} = I_{UB} + I_{FO1A+FO1B} + I_{OL} + I_{OD}$$

$$I_{UB} = \text{Switch operating current (40 mA)}$$

$$I_{OL}/I_{OD} = \text{Load current of monitoring outputs (max. 50 mA per monitoring output)}$$

$$I_{FO1A+FO1B} = \text{Load current of safety outputs } FO1A + FO1B \text{ (2 x max. 150 mA)}$$



### 10.4. Requirements for connecting cables



#### CAUTION

Risk of damage to equipment or malfunctions as a result of incorrect connecting cables.

- › Use connection components and connecting cables from EUCHNER.
- › On the use of other connection components, the requirements in the following table apply. EUCHNER provides no warranty for safe function in case of failure to comply with these requirements.

Observe the following requirements with respect to the connecting cables:

#### For safety switch CTP-...-AP-...-SAB-... or CTP-...-AP-...SII with plug connectors 2 x M12

Parameter	Value	Unit
Conductor cross-section, min.	0.25	mm <sup>2</sup>
R max.	60	Ω/km
C max.	120	nF/km
L max.	0.65	mH/km
Recommended cable type	LIYY 8 x 0.25 mm <sup>2</sup> or 5 x 0.34 mm <sup>2</sup>	

#### For safety switch CTP-...-AP-...-SH-... with plug connector M23 (RC18)

Parameter	Value	Unit
Conductor cross-section, min.	0.25	mm <sup>2</sup>
R max.	60	Ω/km
C max.	120	nF/km
L max.	0.65	mH/km
Recommended cable type	LIFY11Y min. 19-core	

#### For safety switch CTP-...-AP-...-SA-... with plug connector M12, 8-pin

Parameter	Value	Unit
Conductor cross-section, min.	0.25	mm <sup>2</sup>
R max.	60	Ω/km
C max.	120	nF/km
L max.	0.65	mH/km
Recommended cable type	LIYY 8 x 0.25 mm <sup>2</sup>	

### 10.5. Connector assignment of safety switch CTP-...-AP-...-SAB-... with plug connectors 2 x M12

**Wiring diagram A**

Plug connector (view of connection side)	Pin	Designation	Function	Conductor coloring Connecting cable 1)
<p>2 x M12</p>	X 1.1	-	n.c.	WH
	X 1.2	UB	Operating voltage, 24 V DC	BN
	X 1.3	FO1A	Safety output, channel A	GN
	X 1.4	FO1B	Safety output, channel B	YE
	X 1.5	OL	Guard lock monitoring output	GY
	X 1.6	-	n.c.	PK
	X 1.7	OVUB	Electronics operating voltage, 0 V DC	BU
	X 1.8	RST	Reset input	RD
	X 2.1	IMM	Solenoid operating voltage, 0 V DC	BN
	X 2.2	OD	Door position monitoring output	WH
	X 2.3	OI	Diagnostic monitoring output	BU
	X 2.4	IMP	Solenoid operating voltage, 24 V DC	BK
	X 2.5	-	n.c.	GY

1) Only for standard EUCHNER connecting cable.

### 10.6. Connector assignment of safety switch CTP-...-AP-...-SH-... with plug connector M23 (RC18)

**Wiring diagram B**

Plug connector (view of connection side)	Pin	Designation	Function	Conductor coloring Connecting cable 1)
<p>M23 (RC18) with shield spring</p>	1	IMP	Solenoid operating voltage, 24 V DC	VT
	2	-	n.c.	RD
	3	-	n.c.	GY
	4	FO1A	Safety output, channel A	RD/BU
	5	FO1B	Safety output, channel B	GN
	6	UB	Electronics operating voltage, 24 V DC	BU
	7	RST	Reset input	GY/PK
	8	OD	Door position monitoring output	GN/WH
	9	OI	Diagnostic monitoring output	YE/WH
	10	OL	Guard lock monitoring output	GY/WH
	11	-	n.c.	BK
	12	FE	Function earth (must be connected to meet the EMC requirements)	GN/YE
	13	-	n.c.	PK
	14	-	n.c.	BN/GY
	15	-	n.c.	BN/YE
	16	-	n.c.	BN/GN
	17	-	n.c.	WH
	18	IMM	Solenoid operating voltage, 0 V DC	YE
	19	OVUB	Electronics operating voltage, 0 V DC	BN

1) Only for standard EUCHNER connecting cable.

### 10.7. Connector assignment of safety switch CTP-...-AP-...-SA-... with plug connector M12, 8-pin



**Wiring diagram C**

Plug connector (view of connection side)	Pin	Designation	Function	Conductor coloring Connecting cable 1)
<p>1 x M12</p>	1	IMP	Solenoid operating voltage, 24 V DC	WH
	2	UB	Electronics operating voltage, 24 V DC	BN
	3	FO1A	Safety output, channel A	GN
	4	FO1B	Safety output, channel B	YE
	5	OI	Diagnostic monitoring output	GY
	6	OD	Door position monitoring output	PK
	7	OVUB	Electronics operating voltage, 0 V DC	BU
	8	IMM	Solenoid operating voltage, 0 V DC	RD

1) Only for standard EUCHNER connecting cable.

### 10.8. Connector assignment of safety switch CTP-...-AP-...-SII-... with plug connectors 2 x M12, 5-pin

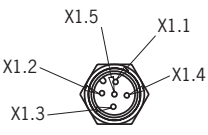
**Wiring diagram D**

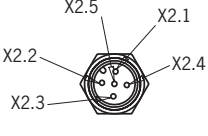
Plug connector (view of connection side)	Pin	Designation	Function	Conductor coloring Connecting cable 1)
	X 1.1	UB	Electronics operating voltage, 24 V DC	BN
	X 1.2	FO1A	Safety output, channel A 	WH
	X 1.3	OVUB	Electronics operating voltage, 0 V DC	BU
	X 1.4	FO1B	Safety output, channel B 	BK
	X 1.5	-	n.c.	GY
	X 2.1	-	n.c.	BN
	X 2.2	-	n.c.	WH
	X 2.3	IMM	Solenoid operating voltage, 0 V DC	BU
	X 2.4	IMP	Solenoid operating voltage, 24 V DC	BK
	X 2.5	-	n.c.	GY

1) Only for standard EUCHNER connecting cable.

### 10.9. Connection of CTP-AP

Connect the device as shown in *Figure 3*. The monitoring outputs can be routed to a control system.

**The following applies to devices with RST input:** The switches can be reset using the RST input. To do this, a voltage of 24 V is applied to the RST input for at least 3 s. The RST input must be connected to 0 V if it is not used.



#### WARNING

In the event of a fault, loss of the safety function due to incorrect connection.  
 ▶ To ensure safety, both safety outputs  FO1A and FO1B must always be evaluated.



#### Important!

▶ The example shows only an excerpt that is relevant for connection of the CTP system. The example illustrated here does not show complete system planning. The user is responsible for safe integration into the overall system. Detailed application examples can be found at [www.euchner.com](http://www.euchner.com). Simply enter the order number of your switch in the search box. You will find all available connection examples for the device in *Downloads*.

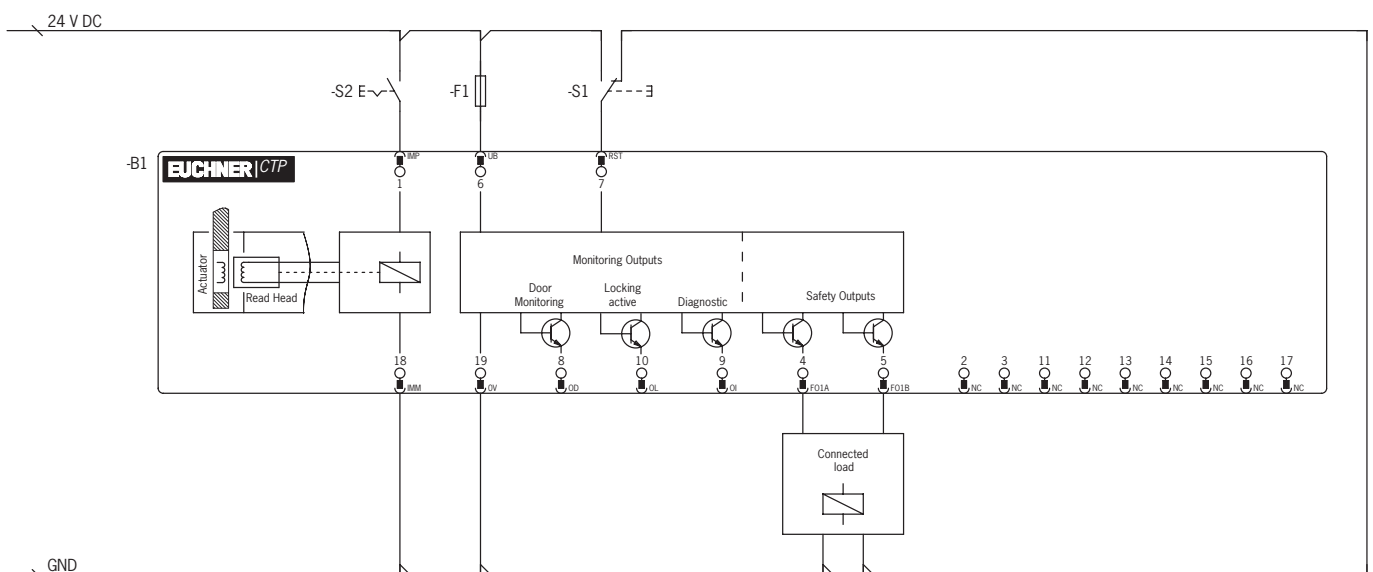



Figure 3: Connection example, version with plug connector M23

**10.10. Notes on operation with safe control systems**

Please observe the following requirements for connection to safe control systems:

- Use a common power supply for the control system and the connected safety switches.
- The device tolerates voltage interruptions on UB of up to 5 ms. Tap the supply voltage directly from the power supply unit. If the power supply is connected to a terminal of a safe control system, this output must provide sufficient electrical current.
- The safety outputs  F01A and F01B can be connected to the safe inputs of a control system. Prerequisite: The input must be suitable for pulsed safety signals (OSSD signals, e.g. from light grids). The control system must tolerate test pulses on the input signals. This normally can be set up by parameter assignment in the control system. Observe the notes of the control system manufacturer. For the pulse duration of your safety switch, refer to chapter 13. *Technical data on page 25.*
- The following applies to single-channel control of guard locking:  
The guard locking (IMM) and the control system must have the same ground.
- For dual-channel control of the solenoid voltage by safe outputs of a control system, the following points must be observed (see also *Figure 4 on page 20*):
  - If possible, switch off the pulsing of the outputs in the control system.
  - Pulses up to a length of max. 5 ms are tolerated.

A detailed example of connecting and setting the parameters of the control system is available for many devices at [www.euchner.com](http://www.euchner.com), in the area *Downloads/Applications/CTP*. The features of the respective device are dealt with there in greater detail.

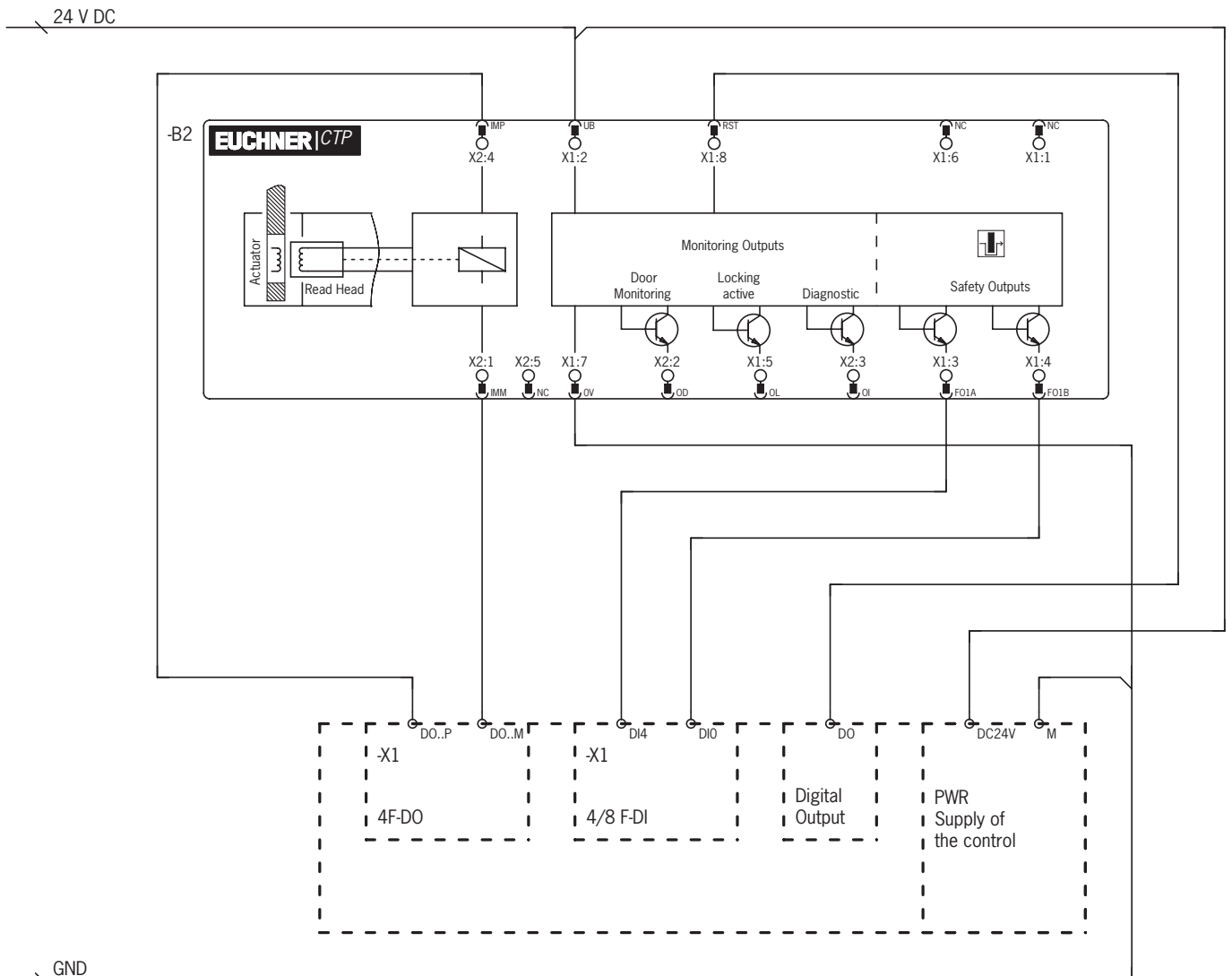
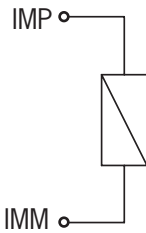

Figure 4: Connection example for the connection to ET200

### 10.11. Connection of guard locking control

#### 10.11.1. Guard locking control for variants with IMM connection

Guard locking solenoid operating voltage,  
24 V DC



Guard locking solenoid operating voltage,  
0 V DC

Figure 5: Connection example with IMM connection

#### 10.11.2. Guard locking control for variants without IMM connection

Guard locking solenoid operating voltage,  
24 V DC

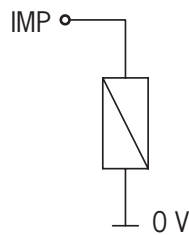

Electronics operating voltage and guard locking  
solenoid operating voltage, 0 V DC

Figure 6: Connection example without IMM connection

## 11. Setup

### 11.1. LED displays

You will find a detailed description of the signal functions in chapter 12. *System status table on page 24.*

LED	Color
STATE	green
LOCK	yellow
DIA	red

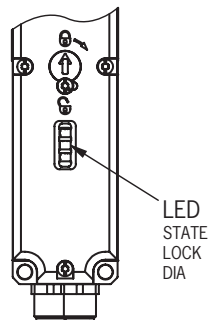

### 11.2. Teach-in function for actuator (only for unicode evaluation)

The actuator must be allocated to the safety switch using a teach-in function before the system forms a functional unit.

During a teach-in operation, the safety outputs are switched off, i.e. the system is in the safe state.

The teach-in operation is fully automatic. The number of possible teach-in operations is unlimited.



#### Tip!

Prior to switching on, close the guard on which the actuator to be taught-in is installed. The teach-in operation starts immediately after switching on. This feature simplifies above all teach-in with series connections and on large installations.



#### Important!

- › The teach-in operation can be performed only if the device does not have any internal fault.
- › Devices in the condition as supplied remain in teach-in standby state until they have successfully taught-in the first actuator. Once taught-in, switches remain in the teach-in standby state for approx. 3 min. after each switch-on.
- › The safety switch disables the code of the preceding device if teach-in is carried out for a new actuator. Teach-in is not possible again immediately for this device if a new teach-in operation is carried out. The disabled code is released again in the safety switch only after a third code has been taught-in.
- › The safety switch can be operated only with the last actuator taught-in.
- › If the switch detects the actuator that was most recently taught-in when in the teach-in standby state, this state is ended immediately and the switch changes to normal operation.
- › The actuator to be taught-in is not activated if it is within the actuating range for less than 30 s.

#### 11.2.1. Actuator teach-in

##### 1. Establish teach-in standby:

- Devices in the condition as supplied: unlimited teach-in standby after switching on.
- Switch already taught-in: teach-in standby is available for approx. 3 min after switching on.

➔ Teach-in standby indication, STATE LED flashes 3x repeatedly.

##### 2. Insert the actuator during teach-in standby.

➔ The automatic teach-in operation starts (duration approx. 30 s).

During the teach-in operation the STATE LED flashes (approx. 1 Hz).

Alternate flashing of the STATE and DIA LEDs acknowledges the successful teach-in operation.

Teach-in errors are indicated by the illumination of the red DIA LED and a flashing code on the green STATE LED (see chapter 12. *System status table on page 24*).

3. Switch off operating voltage UB (min. 3 s).
  - ➔ The code of the actuator that was just taught-in is activated in the safety switch.
4. Switch on operating voltage UB.
  - ➔ The device operates normally.

### 11.3. Functional check



#### WARNING

- Danger of fatal injury as a result of faults in installation and functional check.
- › Before carrying out the functional check, make sure that there are no persons in the danger zone.
  - › Observe the valid accident prevention regulations.

#### 11.3.1. Mechanical function test

The actuator must slide easily into the actuating head. Close the guard several times to check the function. For devices with mechanical release (emergency release or escape release), the correct function of the release must be checked as well.





















#### 11.3.2. Electrical function test











After installation and any fault, the safety function must be fully checked. Proceed as follows:

1. Switch on operating voltage.
  - ➔ The machine must not start automatically.
  - ➔ The safety switch carries out a self-test. The green STATE LED then flashes at regular intervals.
2. Close all guards. In case of guard locking by solenoid force: activate guard locking.
  - ➔ The machine must not start automatically. It must not be possible to open the guard.
  - ➔ The green STATE LED and the yellow LOCK LED are illuminated continuously.
3. Enable operation in the control system.
  - ➔ It must not be possible to deactivate guard locking as long as operation is enabled.
4. Disable operation in the control system and deactivate guard locking.
  - ➔ The guard must remain locked until there is no longer any risk of injury.
  - ➔ It must not be possible to start the machine as long as guard locking is deactivated.

Repeat steps 2 - 4 for each guard.

## 12. System status table

Operating mode	Actuator/door position	Safety outputs F01A and F01B 	Guard lock monitoring output OL	Door position monitoring output OD	LED indicator Output		LOCK (yellow)	State
					STATE (green)	D/A (red) and diagnostic monitoring output OI		
Normal operation	closed	on	on	on		○		Normal operation, door closed and locked
	closed	off	off	on	 1 x inverse	○	○	Normal operation, door closed and <b>not</b> locked
	open	off	off	off	 1 x	○	○	Normal operation, door open
Teach-in operation (only unicode)	open	off	off	off	 3 x	○	○	Device in teach-in standby
	closed	off	X	on	 1 Hz	○	○	Teach-in operation
	X	off	X	X	 ↔ 	○	○	Positive acknowledgment after completion of teach-in operation
Fault display	X	off	X	X	 1 x		○	Error in the teach-in operation (only unicode) Actuator removed from the actuating range prior to the end of the teach-in operation or faulty actuator detected
	X	off	off	off	 2 x		○	Input fault Test pulses on the safety outputs cannot be read due to synchronous tests pulses on UB
	X	off	off	off	 3 x		○	Read error (e.g. actuator faulty)
	X	off	off	off	 4 x		○	Output fault (e.g. short circuit, loss of switching ability)
	X	off	X	X	 5 x		○	Disabled actuator detected
	X	off	off	off	○		X	Internal error

Key to symbols	○		 1 x inverse	 1 Hz	 3 x	 ↔ 	X
		LED not illuminated					
		LED illuminated					
		LED illuminated, briefly goes off 1 x					
		LED flashes at 1 Hz					
		LED flashes three times, and this is then repeated					
		LEDs flash alternately					
	Any state						

After the cause has been remedied, faults can generally be reset by opening and closing the guard. If the fault is still displayed afterward, use the reset function or briefly interrupt the power supply. Contact the manufacturer if the fault could not be reset after restarting.



### Important!

If you do not find the displayed device status in the system status table, this indicates an internal device fault. In this case, you should contact the manufacturer.



### 13. Technical data



#### NOTICE

If a data sheet is included with the product, the information on the data sheet applies.

#### 13.1. Technical data for safety switch CTP-AP

Parameter	Value			Unit
	min.	typ.	max.	
<b>General</b>				
Material - Switch head - Switch housing	Die-cast zinc Reinforced thermoplastic			
Installation orientation	Any			
Degree of protection	IP67/IP69/IP69K			
	(screwed tight with the related mating connector)			
Safety class acc. to EN IEC 61558	III			
Degree of contamination	3			
Mechanical life	1 x 10 <sup>6</sup> operating cycles			
Ambient temperature at UB = 24 V	-20	-	+55	°C
Actuator approach speed, max.	20			m/min
Actuating/extraction/retention force at 20 °C	10/20/20			N
Locking force F <sub>max</sub> <sup>1)</sup>	3,900			N
Locking force F <sub>Zh</sub> <sup>1)</sup> acc. to EN ISO 14119	F <sub>Zh</sub> = F <sub>max</sub> /1.3 = 3,000			N
Weight	Approx. 0.42			kg
Connection (depending on version)	Two plug connectors M12, 5- and 8-pin / one plug connector RC18, 19-pin / one plug connector M12, 8-pin			
Operating voltage UB (reverse polarity protected, regulated, residual ripple < 5%)	24 ± 15% (PELV)			V DC
Current consumption I <sub>UB</sub>	40			mA
For the approval acc. to UL the following applies	Operation only with UL Class 2 power supply or equivalent measures			
Switching load acc. to UL	DC 24 V, class 2			
External fuse (operating voltage UB) <sup>2)</sup>	0.25	-	8	A
External fuse (solenoid operating voltage IMP) <sup>2)</sup>	0.5	-	8	A
Rated insulation voltage U <sub>i</sub>	-	-	50	V
Rated impulse withstand voltage U <sub>imp</sub>	-	-	0.5	kV
Rated conditional short-circuit current	100			A
Resilience to vibration	Acc. to EN 60947-5-3			
EMC protection requirements	Acc. to EN 60947-5-3			
Ready delay	-	-	1	s
Risk time	-	-	260	ms
Turn-on time	-	-	400	ms
Discrepancy time	-	-	10	ms
Test-pulse duration	0.35			ms
Frequency band	120 ... 130			kHz
<b>Safety outputs FO1A/FO1B</b> Semiconductor outputs, p-switching, short circuit-proof				
- Output voltage U <sub>FO1A</sub> /U <sub>FO1B</sub> <sup>3)</sup>				
HIGH U <sub>FO1A</sub> /U <sub>FO1B</sub>	UB - 1.5	-	UB	V DC
LOW U <sub>FO1A</sub> /U <sub>FO1B</sub>	0	-	1	
Switching current per safety output	1	-	150	mA
Utilization category acc. to EN 60947-5-2	DC-13 24V 150 mA Caution: outputs must be protected with a free-wheeling diode in case of inductive loads			
Switching frequency <sup>4)</sup>	0.5			Hz
<b>Monitoring outputs OL, OI, OD</b> p-switching, short circuit-proof				
Output voltage	0.8 x UB	-	UB	V DC
Max. load	-	-	50	mA
<b>Solenoid</b>				
Solenoid operating voltage IMP (reverse polarity protected, regulated, residual ripple < 5%)	DC 24 V +10%/-15%			
Solenoid current consumption I <sub>IMP</sub>	400			mA
Connection rating	6			W
Duty cycle	100			%

Parameter	Value			Unit
	min.	typ.	max.	
<b>Reliability values acc. to EN ISO 13849-1</b>				
Mission time		20		years
<b>Monitoring of guard locking and the guard position</b>				
Category		4		
Performance Level (PL)		e		
PFD <sub>D</sub>		4.1 x 10 <sup>-9</sup> /h		
<b>Control of guard locking</b>				
Category		Depends on external control		
Performance Level (PL)				
PFD <sub>D</sub>				

- 1) Dependent on the actuator used
- 2) Trip characteristic medium slow-blow
- 3) Values at a switching current of 50 mA without taking into account the cable lengths
- 4) Corresponds to the actuation frequency

### 13.1.1. Typical system times

Refer to the technical data for the exact values.

**Ready delay:** After switch-on, the device carries out a self-test. The system is ready for operation only after this time.

**Turn-on time of safety outputs:** The max. reaction time  $t_{on}$  is the time from the moment when the guard is locked to the moment when the safety outputs switch on.

**Risk time according to EN 60947-5-3:** If an actuator moves outside the actuating range, the safety outputs  FO1A and FO1B are switched off after the risk time at the latest.

**Discrepancy time:** The safety outputs  FO1A and FO1B switch with a slight time offset. They have the same signal state no later than after the discrepancy time.

**Test pulses at the safety outputs:** The device generates its own test pulses on the safety outputs  FO1A and FO1B. A downstream control system must tolerate these test pulses.

This can usually be set up in the control systems by parameter assignment. If parameter assignment is not possible for your control system or if shorter test pulses are required, contact our support organization.

The test pulses are output only if the safety outputs are switched on.

### 13.2. Radio frequency approvals

FCC ID: 2AJ58-05

IC: 22052-05



#### FCC/IC-Requirements

This device complies with part 15 of the FCC Rules and with Industry Canada's licence-exempt RSSs. Operation is subject to the following two conditions:

- 1) This device may not cause harmful interference, and
- 2) this device must accept any interference received, including interference that may cause undesired operation.

Changes or modifications not expressly approved by the party responsible for compliance could void the user's authority to operate the equipment.

NOTE: This equipment has been tested and found to comply with the limits for a Class A digital device, pursuant to part 15 of the FCC Rules. These limits are designed to provide reasonable protection against harmful interference when the equipment is operated in a commercial environment. This equipment generates, uses, and can radiate radio frequency energy and, if not installed and used in accordance with the instruction manual, may cause harmful interference to radio communications.

Operation of this equipment in a residential area is likely to cause harmful interference in which case the user will be required to correct the interference at his own expense.

Le présent appareil est conforme aux CNR d'Industrie Canada applicables aux appareils radio exempts de licence. L'exploitation est autorisée aux deux conditions suivantes :

- (1) l'appareil ne doit pas produire de brouillage, et
- (2) l'utilisateur de l'appareil doit accepter tout brouillage radioélectrique subi, même si le brouillage est susceptible d'en compromettre le fonctionnement.

#### Supplier's Declaration of Conformity

##### 47 CFR § 2.1077 Compliance Information

#### Unique Identifier:

CTP-I-AR SERIES  
CTP-I1-AR SERIES  
CTP-I2-AR SERIES  
CTP-IBI-AR SERIES  
CTP-L1-AR SERIES  
CTP-L2-AR SERIES  
CTP-LBI-AR SERIES  
CTP-I-AP SERIES  
CTP-I1-AP SERIES  
CTP-I2-AP SERIES  
CTP-IBI-AP SERIES  
CTP-L1-AP SERIES  
CTP-L2-AP SERIES  
CTP-LBI-AP SERIES

#### Responsible Party – U.S. Contact Information

##### **EUCHNER USA Inc.**

6723 Lyons Street  
East Syracuse, NY 13057

+1 315 701-0315

+1 315 701-0319

info(at)euchner-usa.com

<http://www.euchner-usa.com>

**13.3. Dimension drawing for safety switch CTP...**

Version with plug connectors 2 x M12

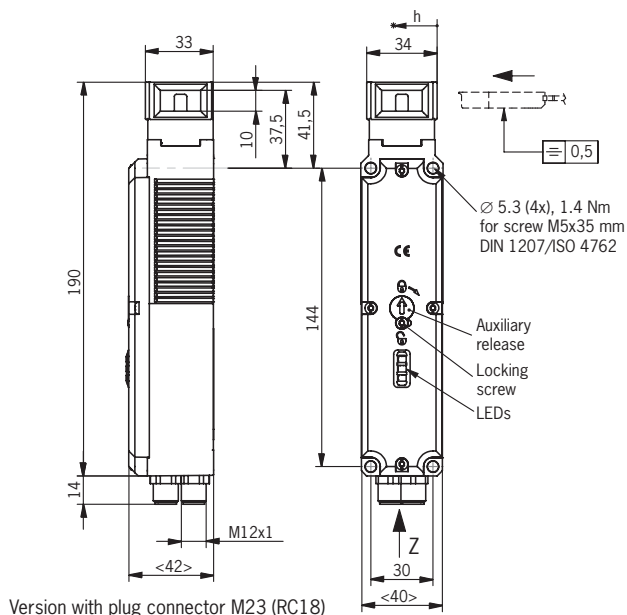

Version with plug connector M23 (RC18)

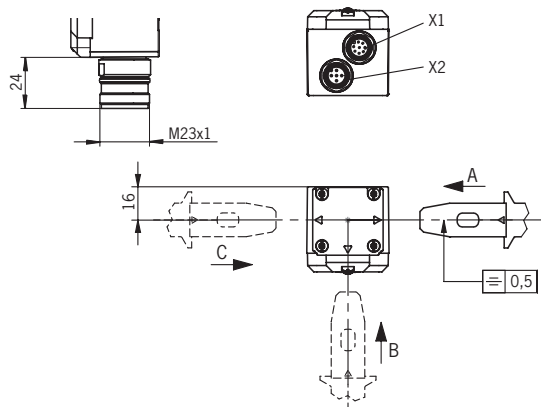

**With escape release**

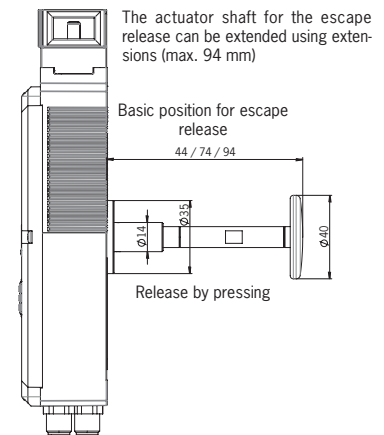

**Plug connectors 2 x M12**

Cable outlet C

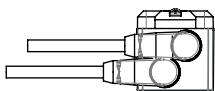

Cable outlet A

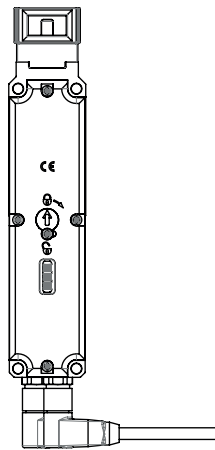
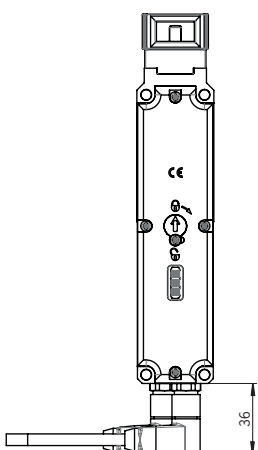
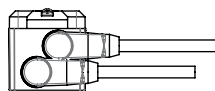

**Plug connector M23**

Cable outlet C

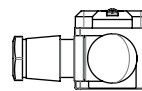

Cable outlet A

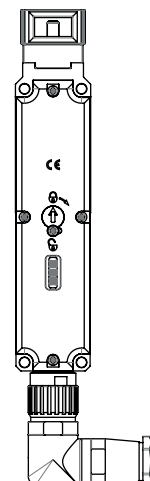
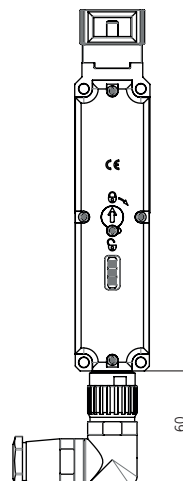
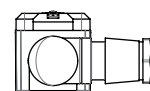

With auxiliary key release

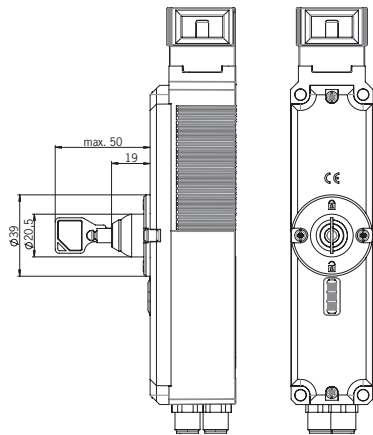

With release, automatic return

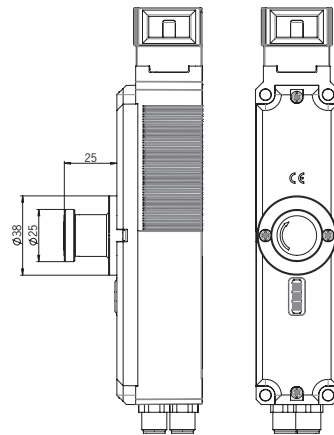

With emergency release

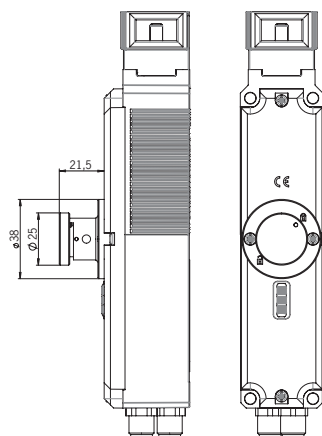

With wire front release

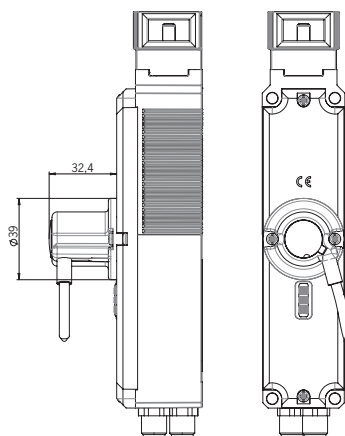

**13.4. Technical data for actuator CTP-...**

Parameter	Value			Unit
	min.	typ.	max.	
Housing material	Fiber reinforced plastic			
Weight	0.03 ... 0.06 (depending on version)			kg
Ambient temperature	-20	-	+55	°C
Degree of protection	IP67/IP69/IP69K			
Mechanical life	1 x 10 <sup>6</sup>			
Locking force, max. - Straight actuator 126015 (red) 122666 (black) - Hinged actuator - Bent actuator		3,900 2,600 2,600 1,500		N
Installation orientation	Any			
Power supply	inductive via read head			

**13.4.1. Dimension drawing for actuator CTP-...**

	Dimension drawing	Min. door radius [mm]	Order no./item
<b>Straight actuators</b>			<p><b>122666</b> A-CH-G-SST-122666</p>
			<p><b>126015</b> A-CH-G-SST-126015</p>

	Dimension drawing	Min. door radius [mm]	Order no./item
Bent actuators	<p>bent, upward</p>		<p><b>122667</b> A-CHW-SST-122667</p>
	<p>bent, downward</p>		<p><b>122668</b> A-CHW-SST-122668</p>

	Dimension drawing	Min. door radius [mm]	Order no./item
Hinged actuators		<p>max. 28    <math>X \begin{smallmatrix} +4 \\ -1 \end{smallmatrix}</math></p> <p>X = 53 mm (122671, 122672) X = 49 mm (122669, 122670)</p>	<p><b>122671</b> A-C-HRL-LS-122671</p>
		<p>max. 28    <math>X \begin{smallmatrix} +4 \\ -1 \end{smallmatrix}</math></p> <p>R &gt; 200    (4)    (Ø 5,5)</p>	<p><b>122672</b> A-C-HRL-LS-122672</p>
Hinged actuators		<p>max. 28    <math>X \begin{smallmatrix} +4 \\ -1 \end{smallmatrix}</math></p> <p>R &gt; 200</p>	<p><b>122675</b> A-C-HR0-LS-122675</p>
		<p>max. 28    <math>X \begin{smallmatrix} +4 \\ -1 \end{smallmatrix}</math></p> <p>R &gt; 200</p>	<p><b>122676</b> A-C-HR0-LS-122676</p>



**Tip!**

Safety screws are included with the actuator.



## 14. Ordering information and accessories



### Tip!

Suitable accessories, e.g. cables or assembly material, can be found at [www.euchner.com](http://www.euchner.com). To order, enter the order number of your item in the search box and open the item view. Accessories that can be combined with the item are listed in *Accessories*.

## 15. Inspection and service



### WARNING

Danger of severe injuries due to the loss of the safety function.

- › If damage or wear is found, the complete switch and actuator assembly must be replaced. Replacement of individual parts or assemblies is not permitted.
- › Check the device for proper function at regular intervals and after every fault. For information about possible time intervals, refer to EN ISO 14119:2013, section 8.2.

Regular inspection of the following is necessary to ensure trouble-free long-term operation:

- › Check the switching function (see chapter 11.3. *Functional check on page 23*)
- › Check all additional functions (e.g. escape release, lockout bar, etc.)
- › Check the secure mounting of the devices and the connections
- › Check for soiling

No servicing is required. Repairs to the device are only allowed to be made by the manufacturer.



### NOTICE

The year of manufacture is given in the laser marking at the bottom right corner. The current version number in the format (V X.X.X) can also be found on the device.

## 16. Service

If servicing is required, please contact:

EUCHNER GmbH + Co. KG  
Kohlhammerstraße 16  
70771 Leinfelden-Echterdingen  
Germany

### Service telephone:

+49 711 7597-500

### E-mail:

support@euchner.de

### Internet:

[www.euchner.com](http://www.euchner.com)

## 17. Declaration of conformity



**EUCHNER**

More than safety.

**EU-Konformitätserklärung**  
**EU declaration of conformity**  
**Déclaration UE de conformité**  
**Dichiarazione di conformità UE**  
**Declaración UE de conformidad**

Original DE  
Translation EN  
Traduction FR  
Traduzione IT  
Traducción ES

2123042-08-07/20

Die nachfolgend aufgeführten Produkte sind konform mit den Anforderungen der folgenden Richtlinien (falls zutreffend):  
*The beneath listed products are in conformity with the requirements of the following directives (if applicable):*  
*Les produits mentionnés ci-dessous sont conformes aux exigences imposées par les directives suivantes (si valable)*  
*I prodotti sotto elencati sono conformi alle direttive sotto riportate (dove applicabili):*  
*Los productos listados a continuación son conforme a los requisitos de las siguientes directivas (si fueran aplicables):*

I:	Maschinenrichtlinie <i>Machinery directive</i> <i>Directive Machines</i> <i>Direttiva Macchine</i> <i>Directiva de máquinas</i>	2006/42/EG 2006/42/EC 2006/42/CE 2006/42/CE 2006/42/CE
II:	Funkanlagen-Richtlinie (RED) <i>Radio equipment directive</i> <i>Directive équipement radioélectrique</i> <i>Direttiva apparecchiatura radio</i> <i>Directiva equipo radioeléctrico</i>	2014/53/EU 2014/53/EU 2014/53/UE 2014/53/UE 2014/53/UE
III:	RoHS Richtlinie <i>RoHS directive</i> <i>Directive de RoHS</i> <i>Direttiva RoHS</i> <i>Directiva RoHS</i>	2011/65/EU 2011/65/EU 2011/65/UE 2011/65/UE 2011/65/UE

Die Schutzziele der Niederspannungsrichtlinie 2014/35/EU und EMV Richtlinie 2014/30/EU werden gemäß Artikel 3.1 der Funkanlagen-Richtlinie eingehalten.  
*The safety objectives of the Low-voltage directive 2014/35/EU and EMC Directive 2014/30/EU comply with article 3.1 of the Radio equipment directive.*  
*Les objectifs de sécurité de la Directive basse tension 2014/35/UE et Directive de CEM 2014/30/UE sont conformes à l'article 3.1 de la Directive équipement radioélectrique.*  
*Gli obiettivi di sicurezza della Direttiva bassa tensione 2014/35/UE e Direttiva CEM 2014/30/UE sono conformi a quanto riportato nell'articolo 3.1 della Direttiva apparecchiatura radio.*  
*Los objetivos de seguridad de la Directiva de bajo voltaje 2014/35/UE y Directiva CEM 2014/30/UE cumplen con el artículo 3.1 de la Directiva equipo radioeléctrico.*

Folgende Normen sind angewandt:  
*Following standards are used:*  
*Les normes suivantes sont appliquées:*  
*Vengono applicate le seguenti norme:*  
*Se utilizan los siguientes estándares:*

a:	EN 60947-5-3:2013	f:	EN IEC 63000:2018 (RoHS)
b:	EN ISO 14119:2013	g:	EN 50364:2018
c:	EN ISO 13849-1:2015	h:	EN 300 330 V2.1.1
d:	EN 62026-2:2013 (ASi)		
e:	EN 60947-5-5:1997/A2:2017		

Bezeichnung der Bauteile <i>Description of components</i> <i>Description des composants</i> <i>Descrizione dei componenti</i> <i>Descripción de componentes</i>	Type	Richtlinie <i>Directives</i> <i>Directive</i> <i>Direttiva</i> <i>Directivas</i>	Normen <i>Standards</i> <i>Normes</i> <i>Norme</i> <i>Estándares</i>	Zertifikats-Nr. <i>No. of certificate</i> <i>Numéro du certificat</i> <i>Numero del certificato</i> <i>Número del certificado</i>
Sicherheitsschalter <i>Safety Switches</i> <i>Interrupteurs de sécurité</i> <i>Finecorsa di sicurezza</i> <i>Interruptores de seguridad</i>	CTP-...	I, II, III	a, b, c, f, g, h	UQS 123565, ET 18080 *
Sicherheitsschalter mit Not-Halt-Einrichtungen <i>Safety Switches with Emergency-Stop facilities</i> <i>Interrupteurs de sécurité avec appareillage arrêt d'urgence</i> <i>Finecorsa di sicurezza con dispositivi di arresto di emergenza</i> <i>Interruptores de seguridad con dispositivos de parada de emergencia</i>	CTP-...AS... CTP-LBI...	I, II, III I, II, III	a, b, c, d, f, g, h a, b, c, f, g, h	UQS 125542 UQS 127798
Betätiger <i>Actuator</i> <i>Actionneur</i> <i>Azionatore</i> <i>Actuador</i>	A-C-...	I, II, III	a, b, c, f, g, h	UQS 123565, ET 18080 *

\* Benannte Stelle  
*Notified Body*  
*Organisme notifié*  
*Sede indicata*  
*Entidad citada*

0340  
DGUV Test  
Prüf- und Zertifizierungsstelle Elektrotechnik  
Fachbereich ETEM  
Gustav-Heinemann-Ufer 130  
50968 Köln

07.07.2020 - NG - HB - Blatt/Sheet/ Page/Pagina/ Página 1  
EUCHNER GmbH + Co. KG Kohlhammerstraße 16 70771 Leinfelden-Echterdingen Tel. +49/711/7597-0 Fax +49/711/753316 www.euchner.de info@euchner.de

Vorlage Rev. 01



# EUCHNER

More than safety.

Genehmigung der umfassenden Qualitätssicherung (UQS) durch die benannte Stelle 0035  
*Approval of the full quality assurance system by the notified body 0035*  
*Approbation du système d'assurance qualité complet par l'organisme notifié 0035*  
*Approvazione del sistema di garanzia di qualità totale da parte dell'organismo notificato 0035*  
*Aprobación del sistema de aseguramiento de calidad total por parte del organismo 0035 notificado*

Die alleinige Verantwortung für die Ausstellung dieser Konformitätserklärung trägt der Hersteller:  
*This declaration of conformity is issued under the sole responsibility of the manufacturer:*  
*La présente déclaration de conformité est établie sous la seule responsabilité du fabricant:*  
*La presente dichiarazione di conformità è rilasciata sotto la responsabilità esclusiva del fabbricante:*  
*La presente declaración de conformidad se expide bajo la exclusiva responsabilidad del fabricante:*

TÜV Rheinland Industrie Service GmbH  
Alboinstr. 56  
12103 Berlin  
Germany

EUCHNER GmbH + Co. KG  
Kohlhammerstraße 16  
70771 Leinfelden-Echterdingen  
Germany

Leinfelden, Juli 2020

EUCHNER GmbH + Co. KG  
Kohlhammerstraße 16  
70771 Leinfelden-Echterdingen  
Germany

i.A. Dipl.-Ing. Richard Holz  
Leiter Elektronik-Entwicklung  
*Manager Electronic Development*  
*Responsable Développement Electronique*  
*Direttore Sviluppo Elettronica*  
*D irector de desarrollo electrónico*

i.A. Dipl.-Ing. (FH) Duc Binh Nguyen  
Dokumentationsbevollmächtigter  
*Documentation manager*  
*Responsible documentation*  
*Responsabilità della documentazione*  
*Agente documenta*

Euchner GmbH + Co. KG  
Kohlhammerstraße 16  
70771 Leinfelden-Echterdingen  
Germany  
info@euchner.de  
www.euchner.com

Edition:  
2124217-07-02/21  
Title:  
Operating Instructions Transponder-Coded Safety Switch  
CTP-AP  
(translation of the original operating instructions)  
Copyright:  
© EUCHNER GmbH + Co. KG, 02/2021

Subject to technical modifications; no responsibility is accepted for the accuracy of this information.