

Connection of serial wired CTP-L1..-AR to Safety Relay ESM-BA..1



Content

Guard locking spring applied – power on released according to EN ISO 14119 (closed-circuit current principle)	2
Components/modules used.....	2
EUCHNER	2
Functional description	3
General.....	3
Connections	3
Safety assessment	3
AR safety switches connected in series	6
Usage of the Reset input	6
Teaching in actuators.....	6
Setting of the Start behavior for ESM-BA..1	7
Manual Start.....	7
Automatic Start	7
Important note – please observe carefully!.....	8

Subject to technical modifications, no responsibility is accepted for the accuracy of this information. © EUCHNER 2016

Guard locking spring applied – power on released according to EN ISO 14119 (closed-circuit current principle)

Safety function Guard locking for personal protection according to EN ISO 14119

Reliability figures according to EN ISO 13849 Category 4, PL e

Components/modules used

EUCHNER

Description	Order no./ item designation
Safety switches with guard locking and guard lock monitoring with transponder technology	123362 / CTP-L1-AR-U-HA-AZ-SH-123362
	123363 / CTP-L1-AR-M-HA-AZ-SH-123363
	123373 / CTP-L1-AR-U-HA-AE-SH-123373
	123374 / CTP-L1-AR-M-HA-AE-SH-123374
Safety relay (base module)	085610 / ESM-BA201
	085613 / ESM-BA301
	097224 / ESM-BA701
	097225 / ESM-BA701P
	097226 / ESM-BA201P
	097230 / ESM-BA301P

Tip: More information and downloads about the above mentioned EUCHNER products can be found at www.EUCHNER.de. Simply enter the order number into the search field.

Functional description

General

The CTP-L1 is a guard locking device according to EN ISO 14119 using the closed-circuit current principle. In this example, the guard locking is controlled by a standard output from a Siemens control system. The two safe outputs of the last CTP are connected to an ESM-BA..1 safety relay.

Connections

Designation	Function	Use in this example
F01A, F01B	Safety outputs. HIGH when the safety guard is closed and locked.	Switch-off of at least one of the outputs leads to a direct switch-off of the safety contacts (13 – 14, 23 – 24, ...) of the safety evaluation module ESM-BA..1. Important: The actual shutdown of the energy which is causing a hazard in a machine is not shown in the example and must be supplemented.
F11A, F11B	Inputs for series connection of AR devices from EUCHNER.	At B2 connected to 24V DC. At B1 connected to F01A and F01B of B2
IMP, IMM	Control input for guard locking solenoid. Connect guard locking to 24 V DC to open.	Activated by switches S1 and S2. Important: According to EN ISO 14119, it shall be ensured that the hazard caused by a machine has disappeared before the guard locking can be released.
OD	Door monitoring output, HIGH, when the door is closed.	Function is not used.
OL	Guard locking monitoring output, HIGH when the door is closed and locked.	Function is not used.
OI	Diagnostics monitoring output, HIGH when the device is in the fault state.	Function is not used.
RST	Input for resetting the switch	Activated via switch S3. All CTP connected in series must be reset simultaneously. Refer to the section "AR safety switches connected in series".

Safety assessment

The CTP-L1 features complete monitoring for faults in the safety-relevant parts and in the connected cables (clock pulses at outputs F01A and F01B). The safety evaluation units ESM-BA..1. achieve PL e, depending on the number of annual switching cycles and the load of the enable paths (see the device's operating instructions for this purpose). The wiring corresponds to the circuit "Two-channel emergency stop with pnp-outputs/OSSD-outputs with short circuit monitoring" in the operating instructions of the ESM-BA..1. In combination with a safety sensor that detects a short circuit for the connected cables (here CTP-L1), the wiring corresponds to PL e. Therefore, PL e in accordance with EN ISO 13849-1 can be achieved for locking mechanism position monitoring of guard locking of the CTP. Series connection of two CTP-L1 devices does not reduce the achievable PL.

A safety assessment for control of guard locking is not part of this example and must be supplemented for the respective machine by the design engineer in accordance with the risk assessment.

Important: Switch-off of the energy and any necessary monitoring energy switch-off (feedback loop) of the hazard are not part of this document and must be added in accordance with the risk assessment for the machine. In this example, the safety evaluation unit without feedback loop and without start button is used. Please refer to the operating instructions of the safety evaluation unit used for more information.

Principle circuit diagram (shown with ESM-BA301)

In the example Automatic Start of the ESM-BA301 is used

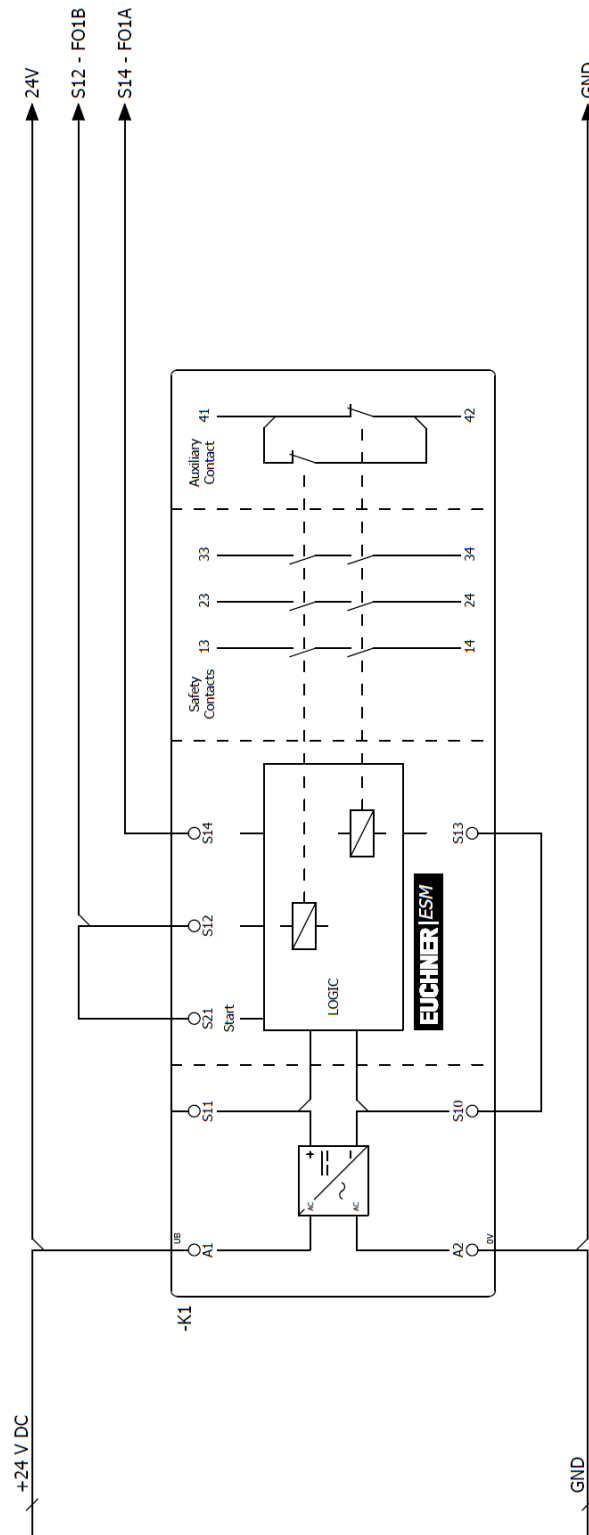

Figure 1

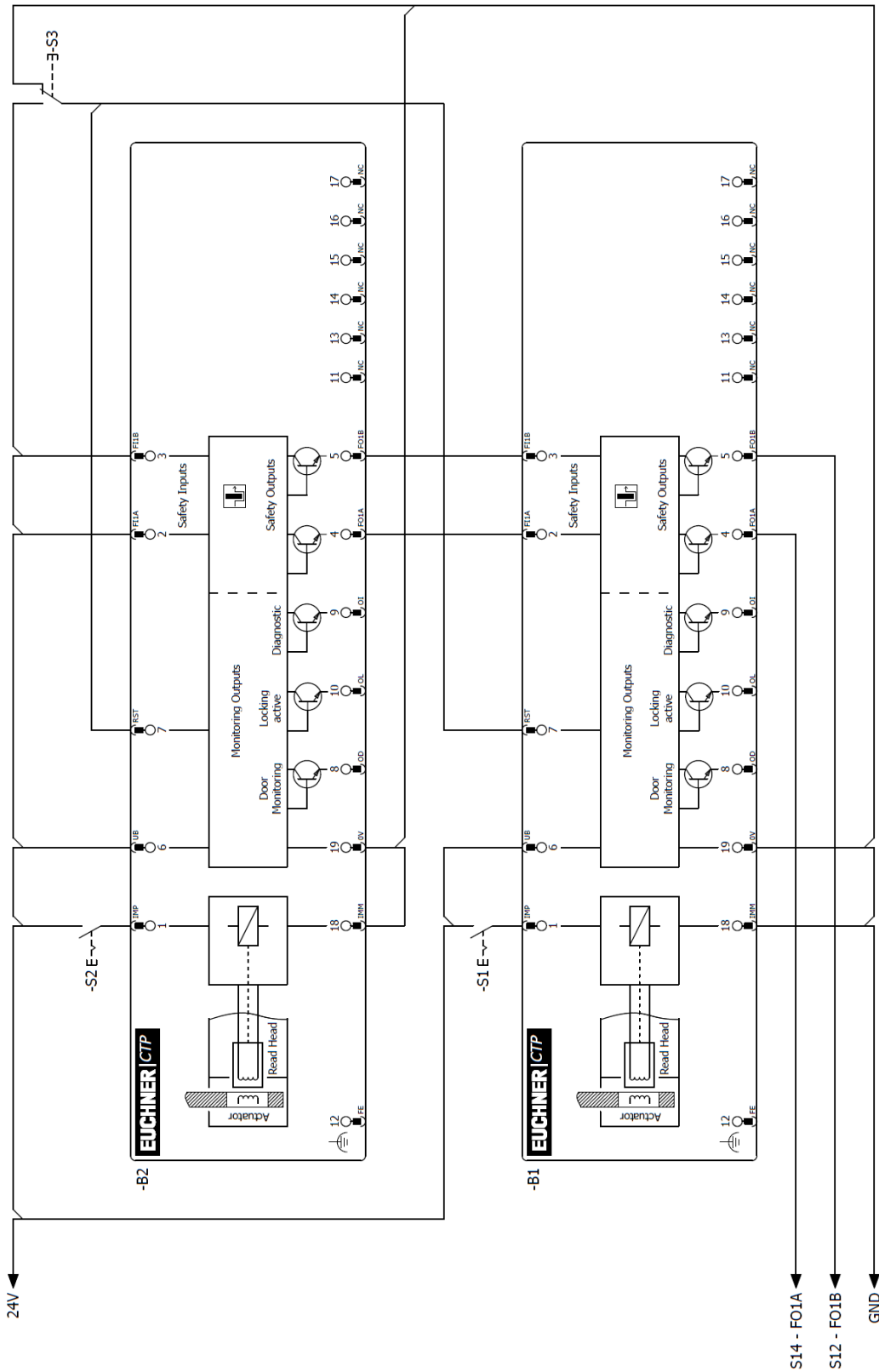

Figure 2

AR safety switches connected in series

Usage of the Reset input

In a series connection the reset must always be connected to all switches. A common signal must be used for all switches in the chain. This can be a changeover switch or the output of a control system. A button is not suitable because Reset must always be connected to GND during operation.

The reset is used to synchronize the switches connected in series. This action is necessary if synchronization is lost due to external effects. This situation may be caused by switching off one of the switches in the series. All switches in the chain must always be reset together, as otherwise the synchronization will fail and as a result the safety outputs will not switch.

Teaching in actuators

It is recommended not to teach-in the actuators in the series circuit, but to teach them in one by one instead.

It is often only possible to teach-in actuators in an installed chain with limitations. Work on the wiring (e.g. during device replacement) should in general be performed in a de-energized state. On certain systems, it is nevertheless necessary to perform this work and subsequent teach-in during ongoing operation.

To make this action possible, the input RST must be connected as shown in Figures 1 and 2.

Proceed as follows:

1. Open the safety door on which the switch or actuator is to be replaced.
2. Mount the new switch or actuator and close all safety doors in the chain.
3. Actuate the reset for at least 3 s (24 V on RST).
4. On the safety switch that is positioned at a new actuator, the green State LED flashes at approx. 1 Hz and the actuator is taught-in. This happens for approx. 30 seconds - do not switch off during this time and do not actuate reset!

The teach-in operation has successfully ended when the green State LED and the red DIA LED blink alternately.

Actuate the reset for at least 3 s (24 V on RST).

The system re-starts and then operates normally again.

Setting of the Start behavior for ESM-BA..1

Only with the following settings does the safety relay ESM-BA..1 operates correctly with a CTP-L1.

Manual Start

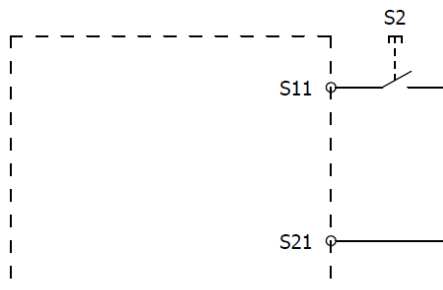

Automatic Start

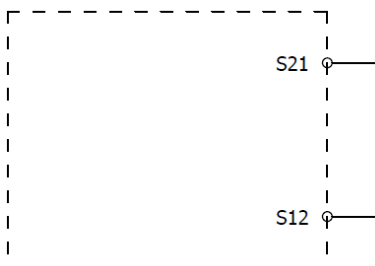

Important note – please observe carefully!

This document is intended for a design engineer who possesses the requisite knowledge in safety engineering and knows the applicable standards, e.g. through training for qualification as a safety engineer. Only with the appropriate qualification is it possible to integrate the introduced example into a complete safety chain.

The example represents only a part of a complete safety chain and does not fulfill any safety function on its own. In order to fulfill a safety function, the energy switch-off function for the hazard location and the software within the safety evaluation must also be considered, for example.

The introduced applications are only examples for solving certain safety tasks for protecting safety guards. The examples cannot be comprehensive due to the application-dependent and individual protection goals within a machine/installation.

If questions pertaining to this example remain open, please contact us directly.

In accordance with Machinery Directive 2006/42/EC, the design engineer of a machine or installation is obligated to perform a risk assessment and take measures to reduce the risk. When doing this, the engineer must comply with the applicable national and international standards. Standards generally represent the current state of the art. Therefore, the design engineer should continuously inform himself about changes in the standards and adapt his considerations to them. Relevant standards include EN ISO 13849 and EN 62061. This application must be regarded only as assistance for the considerations about safety measures.

The design engineer of a machine/installation is obligated to assess the safety technology himself. The examples must not be used for assessment, because only a small excerpt of a complete safety function was considered in terms of safety engineering here.

In order to be able to use the safety switch applications correctly on safety guards, it is indispensable to observe the standards EN ISO 13849-1, EN ISO 14119 and all relevant C-standards for the respective machine type. Under no circumstances does this document replace the engineer's own risk assessment, and it cannot serve as the basis for a fault assessment.

Particularly in case of a fault exclusion, it must be noted that this can be performed only by the design engineer of a machine or installation and requires a reason. A general fault exclusion is not possible. More information about fault exclusion can be found in EN ISO 13849-2.

Changes at products or within assemblies from third-party suppliers used in this example can lead to the function no longer being ensured or the safety assessment having to be adapted. In any event, the information in the operating instructions on the part of EUCHNER, as well as on the part of third-party suppliers, must be taken as the basis before this application is integrated into an overall safety function. If contradictions should arise between the operating instructions and this document, please contact us directly.

Use of brand and company names

All mentioned brand and company names are property of the respective manufacturers. The use is only for clear identification of compatible peripheral devices and environment of operation in combination with our products.