

Connection of serial wired MGB-L1..-AR, CES-AR and CET3-AR to Siemens ET 200S



Content

Guard locking spring applied – power on released according to EN ISO 14119 (closed-circuit current principle)	2
Components/modules used.....	2
EUCHNER	2
Interlocking device according to EN ISO 14119	3
Components/modules used.....	3
EUCHNER	3
Other	3
Functional description	4
General.....	4
CET Connections	4
MGB Connections	5
CES Connections.....	5
Safety assessment	6
Device configuration for MGB	6
DIP switches – Setting system family AR.....	6
DIP switches – Setting guard lock monitoring activated	6
Principle circuit diagram.....	7
AR safety switches connected in series	9
Usage of the Reset input	9
Teaching in actuators.....	9
Parameter assignment in the control system	10
Input 4/8 F-DI	10
Important note – please observe carefully!.....	12

Guard locking spring applied – power on released according to EN ISO 14119 (closed-circuit current principle)

Safety function

Guard locking for personal protection according to EN ISO 14119

Reliability figures according to EN ISO 13849 Category 4, PL e

Components/modules used

EUCHNER

Description	Order no./item designation Set	Order no./item designation Evaluation Units
Safety system MGB, Guard locking with guard locking monitoring	110613 / MGB-L1H-ARA-R-110613	110792 / MGB-L1-ARA-AA2A1-S1-R-110792
	110614 / MGB-L1H-ARA-L-110614	110793 / MGB-L1-ARA-AA2A1-S1-L-110793
	113747 / MGB-L1HE-ARA-R-113747	113746 / MGB-L1-ARA-AF5A1-S1-R-113746
	113749 / MGB-L1HE-ARA-L-113749	113748 / MGB-L1-ARA-AF5A1-S1-L-113748
	121216 / MGB-L1HE-ARA-R-121216	121215 / MGB-L1-ARA-AM5A1-S1-R-121215
	121218 / MGB-L1HE-ARA-L-121218	121217 / MGB-L1-ARA-AM5A1-S1-L-121217

Description	Order no./item designation
Safety switches with guard locking and guard lock monitoring with transponder technology	110103 / CET3-AR-CRA-AH-50X-SH-110103
	111725 / CET3-AR-CRA-AH-50F-SH-C2312-111725
	113023 / CET3-AR-CRA-AH-50F-SH-C2353-113023
	113024 / CET3-AR-CRA-AH-50X-SH-C2290-113024
	113142 / CET3-AR-CRA-AH-50F-SH-C2354-113142
	113143 / CET3-AR-CRA-AH-50X-SH-C2354-113143
	113148 / CET3-AR-CRA-AH-50F-SH-113148
	113151 / CET3-AR-CRA-AH-50X-SH-C2333-113151
	114088 / CET3-AR-CRA-AH-50X-SH-C2290-114088
	114505 / CET3-AR-CRA-AH-50F-SH-C2333-114505
	114647 / CET3-AR-CDA-AH-50F-SH-114647

Tip: More information and downloads about the above mentioned EUCHNER products can be found at www.EUCHNER.de. Simply enter the order number into the search field.

Interlocking device according to EN ISO 14119

Safety function Interlocking device according to EN ISO 14119

Reliability figures according to EN ISO 13849 Category 4, PL e

Components/modules used

EUCHNER

Description	Order no./item designation
Safety switches with transponder technology	098582 / CES-AR-C01-EH-SA
	098941 / CES-AR-C01-AH-SA
	098942 / CES-AR-C01-CH-SA
	105745 / CES-AR-CR2-CH-SA-105745
	105746 / CES-AR-CR2-AH-SA-105746
	105747 / CES-AR-CL2-CH-SA-105747
	105748 / CES-AR-CL2-AH-SA-105748
	105750 / CES-AR-CR2-CH-SG-105750
	105751 / CES-AR-CR2-AH-SG-105751
	105752 / CES-AR-CL2-CH-SG-105752
	105753 / CES-AR-CL2-AH-SG-105753
	110939 / CES-AR-CR2-CH-SA-110939
	112711 / CES-AR-CR2-CH-SG-112711
	112712 / CES-AR-CL2-CH-SG-112712
	112928 / CES-AR-CR2-CH-SA-112928
	112929 / CES-AR-CL2-CH-SA-112929
115792 / CES-AR-CR2-CH-SA-115792	
115793 / CES-AR-CL2-CH-SA-115793	

Tip: More information and downloads about the above mentioned EUCHNER products can be found at www.EUCHNER.de. Simply enter the order number into the search field.

Other

Description	Items
ET 200S, Interface module IM151-3 PN HF	6ES7151-3BA23-0AB0
SIMATIC DP, Power module PM-E	6ES7138-4CA01-0AA0
Digital Electronic module 4/8 F-DI DC24V PROFIsafe	6ES7138-4FA00-0AB0
	6ES7138-4FA03-0AB0
	6ES7138-4FA04-0AB0
Digital electronic module 8 DO DC24V/0.5A	6ES7132-4BF00-0AA0
Digital Electronic module 8 DI DC24V	6ES7131-4BF00-0AA0

Functional description

General

MGB-L1 and CET3 are guard locking devices according to EN ISO 14119 using the closed-circuit current principle. CES-AR is part of an interlocking device in accordance with EN ISO 14119. In this example, the guard locking of the CET and the MGB are controlled respectively by a standard output from a Siemens control system. Here 1 CES, 1 CET3 and 1 MGB-L1 are connected in series. The two safe outputs of the MGB-L1 are connected to a safe input of an ET 200S.

In this example, MGB-L1 with the version 2.0.0 or newer are used in the configuration "system family AR". Please note that the circuit must be changed if older MGB versions are used.

CET Connections

Designation	Function	Use in this example
OA, OB	Safety outputs. HIGH when the safety guard is closed and locked.	Switch-off of at least one of the outputs must lead to shutdown of the machine or installation via the connected control system. Important: The actual shutdown of the energy causing a hazard in a machine is not shown in the example and must be supplemented.
IA, IB	Inputs for series connection of AR devices from EUCHNER.	Connected to OA and OB of the previous device.
+UCM, 0V (UCM)	Control input for guard locking solenoid. Connect guard locking to 24 V DC to open.	Connected to a standard output of the ET 200S. Important: According to EN ISO 14119, it shall be ensured that the hazard caused by a machine has disappeared before the guard locking can be released.
OUT	Monitoring output. HIGH when outputs OA and OB are switched on (safety guard closed and locked).	Connected to a standard input of the ET 200S.
OUTD	Door monitoring output. HIGH when the actuator is within the operating distance and the CET is ready to engage guard locking (safety guard closed).	Connected to a standard input of the ET 200S.
LED1	Input for controlling the installed red LED.	Function is not used
LED2	Input for controlling the installed green LED	Function is not used
J	Teach-in input	The corresponding input must be connected to 24 V DC for actuator teach-in (for this purpose, see the operating instructions ¹⁾). Important: for teach-in operation terminal 0V (UCM) has to be connected to 0V not to a different potential or to an output. The input must be unconnected during operation.
RST	Input for resetting the switch	Connected to a standard output of the ET 200S. All safety switches connected in series must reset simultaneously. See the section entitled "AR safety switches connected in series".

1) You can find the current operating instructions on the Internet at www.euchner.de. Simply enter the order number into the search field.

MGB Connections

Designation	Function	Use in this example
F01A, F01B	Safety outputs. HIGH when the safety guard is closed and locked.	Switch-off of at least one of the outputs must lead to shutdown of the machine or installation via the connected control system. Important: The actual shutdown of the energy which is causing a hazard in a machine is not shown in the example and must be supplemented.
FI1A, FI1B	Inputs for series connection of AR devices from EUCHNER.	Connected to F01A and F01B of the previous device. Important: DIP switches 1 and 2 in the MGB must be set to OFF position. It is essential to observe the MGB operating instructions for this purpose.
IMP (up to V2.2.2) IMP1 (from V3.0.0)	Control input for guard locking solenoid. Connect guard locking to 24 V DC to open.	Connected to a standard output of the ET 200S. Important: According to EN ISO 14119, it shall be ensured that the hazard caused by a machine has disappeared before the guard locking can be released.
OT	Bolt tongue monitoring output, HIGH when the door is closed and the bolt tongue is inserted in the locking module.	Connected to a standard input of the ET 200S.
OI	Diagnostics monitoring output, HIGH when the device is in the fault state.	Connected to a standard input of the ET 200S.
RST	Input for resetting the switch	Connected to a standard output of the ET 200S. All safety switches connected in series must reset simultaneously. See the section entitled "AR safety switches connected in series".
S1 (10 – 11, 13 – 14)	Potential-free contacts of the installed emergency stop command device	Not used in this example. Important: The emergency stop function must be integrated into the emergency stop chain of the safety control system in accordance with the risk analysis.
H2 (16), H3 (18)	Control inputs for the LEDs in buttons S2 and S3	Not used in this example.
S2 (15), S3 (17)	Monitoring outputs for the installed buttons S2 and S3	Not used in this example.

CES Connections

Designation	Function	Use in this example
OA, OB	Safety outputs. HIGH when the safeguarding device is closed and the actuator is in operating distance.	Switch-off of at least one of the outputs must lead to shutdown of the machine or installation via the connected control system. Important: The actual shutdown of the energy which is causing a hazard in a machine is not shown in the example and must be supplemented.
IA, IB	Inputs for series connection of AR devices from EUCHNER.	Connected to 24V DC.
OUT	Monitoring output. HIGH when outputs OA and OB are switched on (safety guard closed).	Connected to a standard input of the ET 200S.
RST	Input for resetting the switch	Connected to a standard output of the ET 200S. All safety switches connected in series must be reset simultaneously. Refer to the section "AR safety switches connected in series".

Safety assessment

CET3, MGB and CES feature complete monitoring for faults in the safety-relevant parts and in the connected cables (clock pulses at outputs OA and OB and FO1A, FO1B respectively). With the device's own pulsing, switch-off or non-connection of the clock signals from the control system's safe inputs does not lead to a reduction in the PL. The example achieves PL e in accordance with EN ISO 13849-1 for position monitoring of the locking mechanism of guard locking. Series connection of CET3, MGB and CES devices does not reduce the achievable PL.

A safety assessment for control of guard locking is not part of this example and must be supplemented for the respective machine by the design engineer in accordance with the risk assessment.

Device configuration for MGB

The device can be configured using DIP switches. To change the device settings, please refer to the operating instructions for the MGB.

Tip: The operation manual can be found at www.EUCHNER.de. Simply enter the order number into the search field.

DIP switches – Setting system family AR

Switches 1 and 2 must be set to OFF position (normally the factory setting).

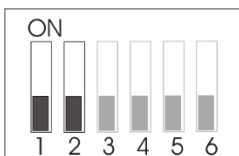

DIP switches – Setting guard lock monitoring activated

Switches 3 and 4 must be set to OFF position (normally the factory setting).

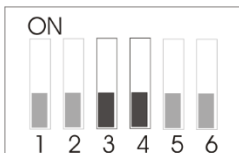

Principle circuit diagram

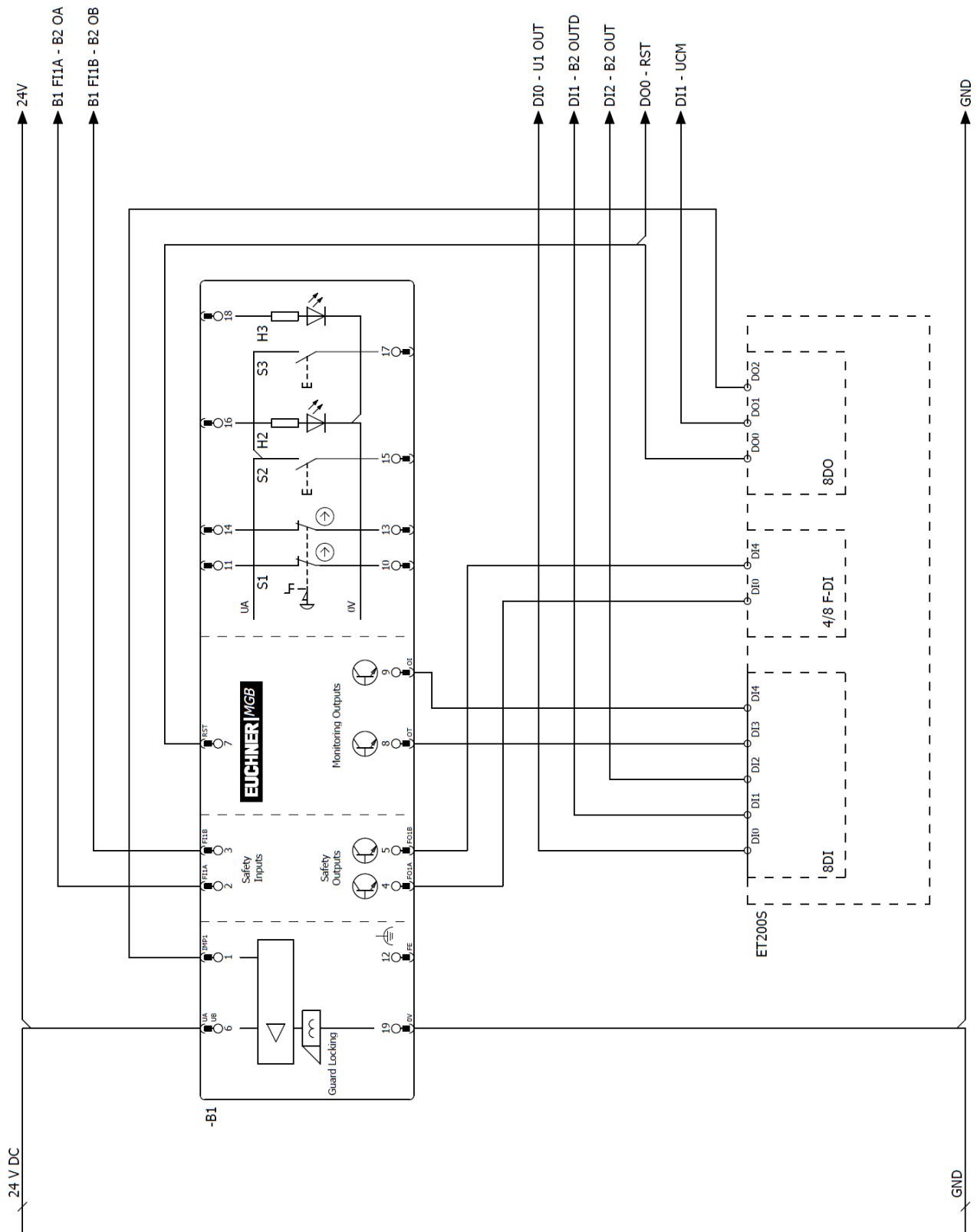

Figure 1

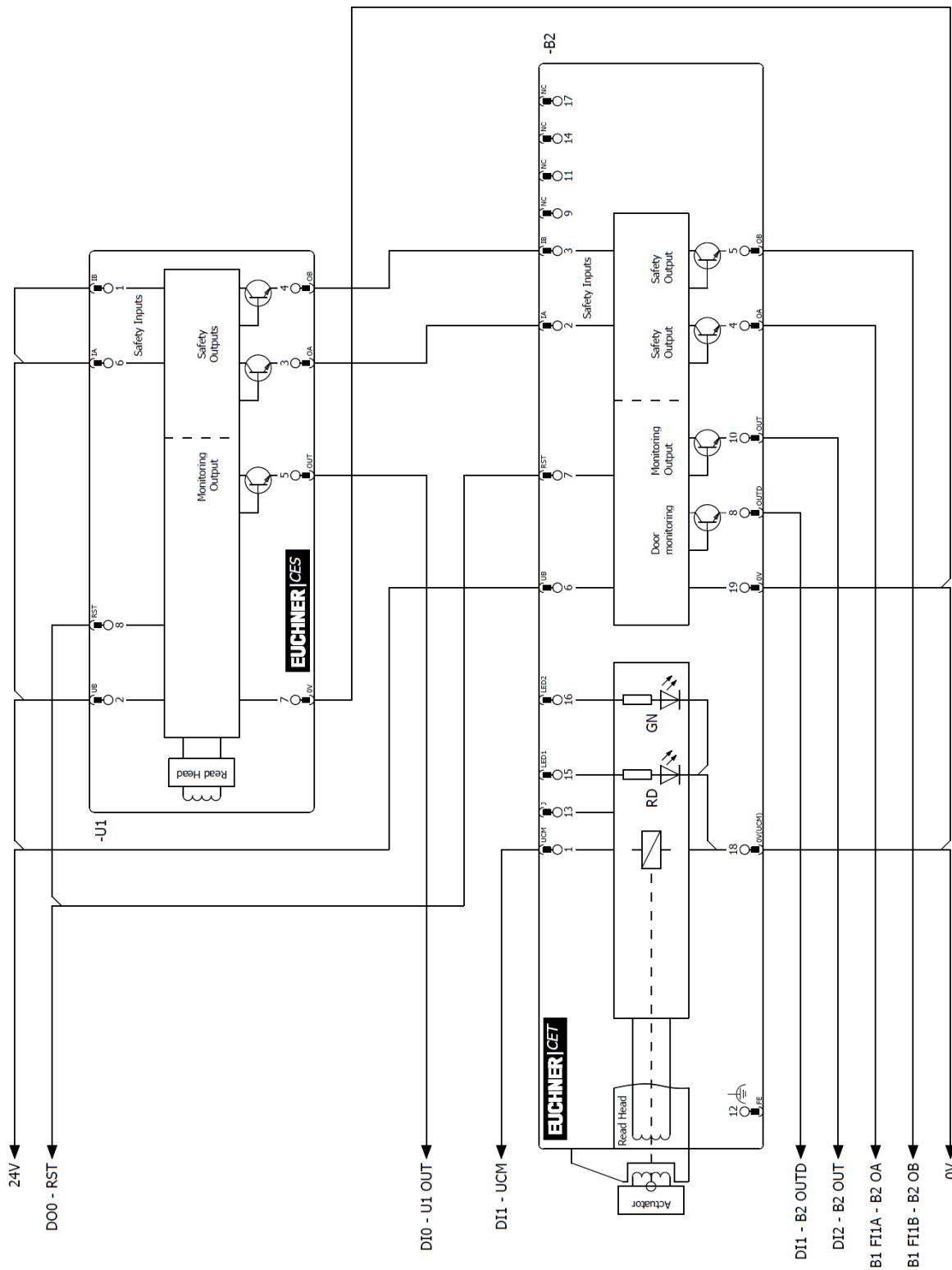

Figure 2

AR safety switches connected in series

Usage of the Reset input

In a series connection the reset must always be connected to all switches. A common signal must be used for all switches in the chain. This can be a changeover switch or the output of a control system. A button is not suitable because Reset must always be connected to GND during operation.

The reset is used to synchronize the switches connected in series. This action is necessary if synchronization is lost due to external effects. This situation may be caused by switching off one of the switches in the series. All switches in the chain must always be reset together, as otherwise the synchronization will fail and as a result the safety outputs will not switch.

Teaching in actuators

It is recommended not to teach-in the actuators in the series circuit, but to teach them in one by one instead.

It is often only possible to teach-in actuators in an installed chain with limitations. Work on the wiring (e.g. during device replacement) should in general be performed in a de-energized state. On certain systems, it is nevertheless necessary to perform this work and subsequent teach-in during ongoing operation.

To make this action possible, the input RST must be connected as shown in Figures 1 and 2.

Proceed as follows:

1. Open the safety door on which the switch or actuator is to be replaced.
2. Mount the new switch or actuator and close all safety doors in the chain.
3. Actuate the reset for at least 3 s (24 V on RST).
4. On the safety switch that is positioned at a new actuator, the green State LED flashes at approx. 1 Hz and the actuator is taught-in. This happens for approx. 1 minute - do not switch off during this time and do not actuate reset!
The teach-in operation has ended when all LEDs on the devices are off, except POWER LED in MGB.
5. Actuate the reset for at least 3 s (24 V on RST).
The system re-starts and then operates normally again.

Parameter assignment in the control system

Input 4/8 F-DI

This parameter assignment applies only for the following assemblies:

- 6ES7138-4FA03-0AB0
- 6ES7138-4FA04-0AB0

Parameter	Value
F-Parameter	Corresponding to the use in Profibus/Profinet
Input delay	3 (ms) or longer
Short-circuit test	Cyclic
Behavior after channel faults	Optional
Sensor supply	External
Evaluation of the sensors	1oo2
Type of sensor interconnection	Dual-channel equivalent
Other parameters	Optional

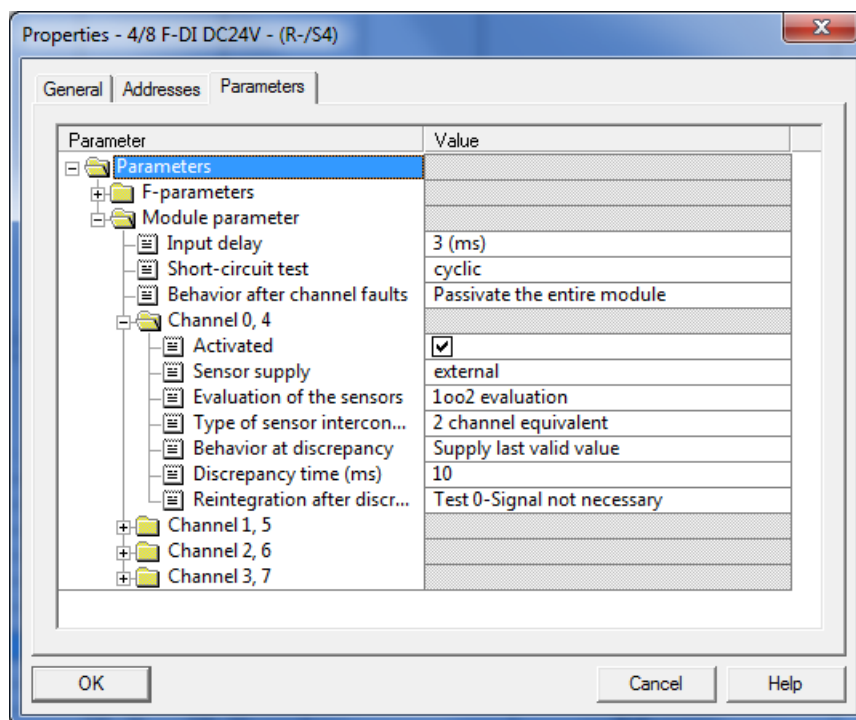

Figure 3

Input 4/8 F-DI (continued)

This parameter assignment applies only for the following assemblies:

- 6ES7138-4FA00-0AB0

Parameter	Value
F-Parameter	Corresponding to the use in Profibus/Profinet
Input delay	3 (ms) or longer
Short-circuit test	Lock
Behavior after channel faults	Optional
Evaluation of the sensors	1oo2
Type of sensor interconnection	Dual-channel equivalent
Other parameters	Optional

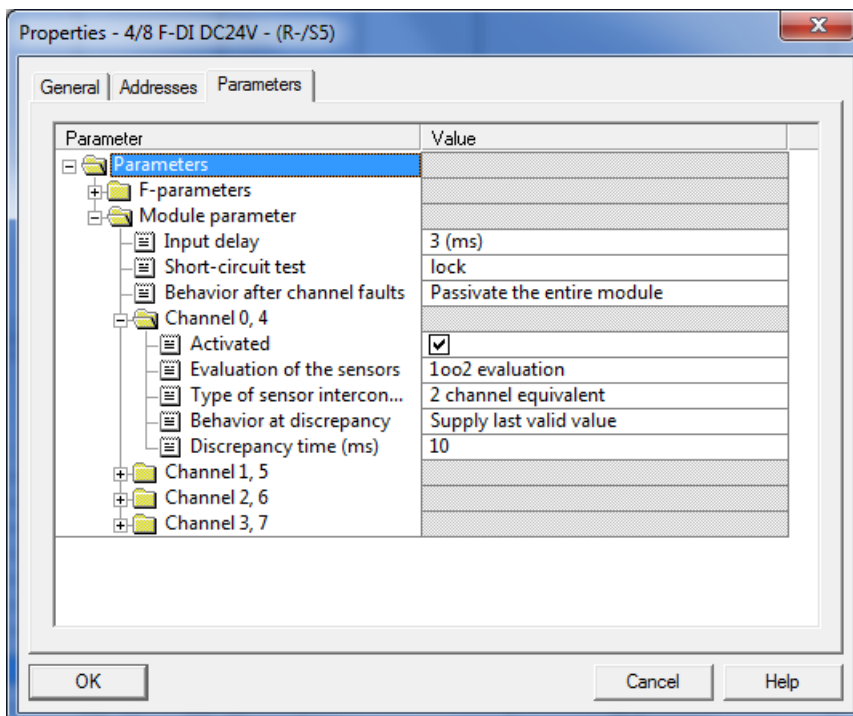

Figure 4

Important note – please observe carefully!

This document is intended for a design engineer who possesses the requisite knowledge in safety engineering and knows the applicable standards, e.g. through training for qualification as a safety engineer. Only with the appropriate qualification is it possible to integrate the introduced example into a complete safety chain.

The example represents only a part of a complete safety chain and does not fulfill any safety function on its own. In order to fulfill a safety function, the energy switch-off function for the hazard location and the software within the safety evaluation must also be considered, for example.

The introduced applications are only examples for solving certain safety tasks for protecting safety guards. The examples cannot be comprehensive due to the application-dependent and individual protection goals within a machine/installation.

If questions pertaining to this example remain open, please contact us directly.

In accordance with Machinery Directive 2006/42/EC, the design engineer of a machine or installation is obligated to perform a risk assessment and take measures to reduce the risk. When doing this, the engineer must comply with the applicable national and international standards. Standards generally represent the current state of the art. Therefore, the design engineer should continuously inform himself about changes in the standards and adapt his considerations to them. Relevant standards include EN ISO 13849 and EN 62061. This application must be regarded only as assistance for the considerations about safety measures.

The design engineer of a machine/installation is obligated to assess the safety technology himself. The examples must not be used for assessment, because only a small excerpt of a complete safety function was considered in terms of safety engineering here.

In order to be able to use the safety switch applications correctly on safety guards, it is indispensable to observe the standards EN ISO 13849-1, EN ISO 14119 and all relevant C-standards for the respective machine type. Under no circumstances does this document replace the engineer's own risk assessment, and it cannot serve as the basis for a fault assessment.

Particularly in case of a fault exclusion, it must be noted that this can be performed only by the design engineer of a machine or installation and requires a reason. A general fault exclusion is not possible. More information about fault exclusion can be found in EN ISO 13849-2.

Changes at products or within assemblies from third-party suppliers used in this example can lead to the function no longer being ensured or the safety assessment having to be adapted. In any event, the information in the operating instructions on the part of EUCHNER, as well as on the part of third-party suppliers, must be taken as the basis before this application is integrated into an overall safety function. If contradictions should arise between the operating instructions and this document, please contact us directly.

Use of brand and company names

All mentioned brand and company names are property of the respective manufacturers. The use is only for clear identification of compatible peripheral devices and environment of operation in combination with our products.